

RHM 160 - The world's largest 12" Coriolis Mass Flowmeter 2 parallel 6 inch measuring loops

The RHM 160 can measure flow rates up to 1500 t/hr with the patented Omega shape meter technology [manufactured by Rheonik](#), the mass flow meter experts.

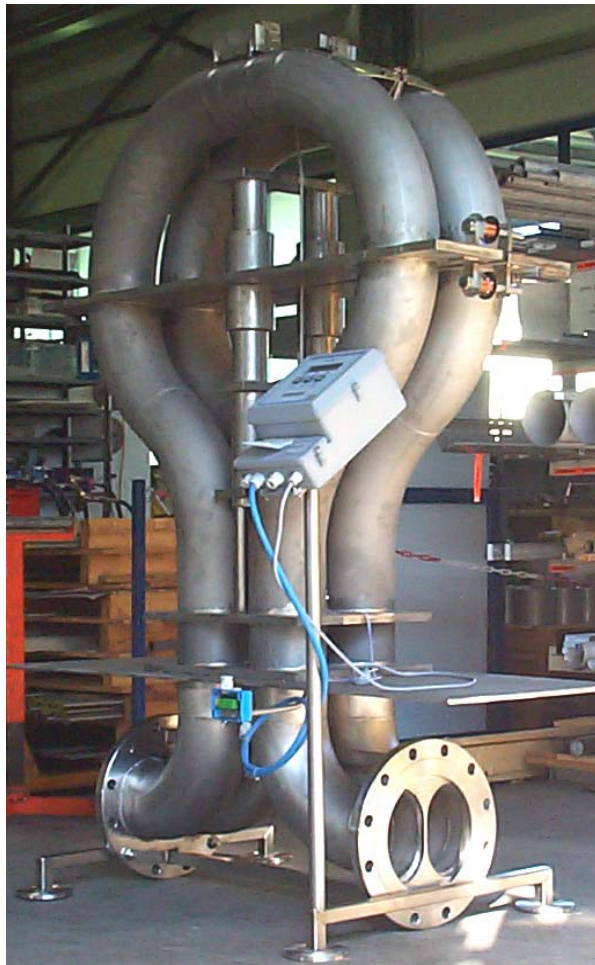

GENERAL

The RHM 160 is the world's largest Coriolis Mass Flowmeter which has been designed for very high flow rates or applications which require extremely low pressure drops. With 10" or 12" flanged process connections, this meter can easily be fitted to existing pipe work. This unique design, which offers excellent performance and reliability, has created the most satisfied customers worldwide. Unlike other mass flowmeter manufacturers, Rheonik uses a patented torsion rod swinger with the Omega shape and support bars which results in high accuracy measurement, which is independent of pressure, even at very low flow velocities. The meter also has extremely good repeatability and high stability for critical applications.

APPLICATIONS

- Loading of boats, vessels, rail road tank wagons
- Any other kind of custody transfer measurement
- Highly viscous media (low pressure drop and excellent performance at low flow conditions)
- Oil exploration

FEATURES

- Short face to face length
- Patented Torsion Swinger
- Customer adaptations possible for application optimized solutions
- Typical measuring ranges from 500 to 25.000 kg/min
- Flow Accuracy better than 0.2%
- Repeatability better than 0.05%
- EEx Approvals (i.e. ATEX, CSA, ...)
- Custody Transfer Approvals (i.e. PTB, NMI, ...)

ADVANTAGES

- High flow rates for fast filling
- Patented torsion swinger design assures most stable and drift free measurement
- Increased signal to noise ratio by torsion swinger
- Longest life time and increased safety (low stress in welds and increased wall thickness against abrasion)
- No moving parts, practically no maintenance
- Two Measuring loops with each 6 inch - a truly large meter.

PERFORMANCE RHM 160

Max Flow 25000 kg/min (55115 lb/min)

1) Standard Models

Rates / turndown ratio	in kg/min	in lb/min	error in % of reading
nominal rate Q_{nom}	23000	50715	0.20
$0.2 * Q_{max}$ (5:1)	5000	11023	0.20
$0.1 * Q_{max}$ (10:1)	2500	5511	0.20
$0.05 * Q_{max}$ (20:1)	1250	2755	0.20
$0.02 * Q_{max}$ (50:1)	500	1102	0.50

Typical ΔP in bar (psi)		
1 cP	100 cP	1000 cP
0.4 (5.6)	0.6 (9.1)	0.8 (12)
~ 0 (0.3)	~ 0 (0.6)	0.2 (2)
~ 0 (0.1)	~ 0 (0.2)	~ 0 (1)
~ 0 (0)	~ 0 (0)	~ 0 (1)
~ 0 (0)	~ 0 (0)	~ 0 (0)

2) Optimized Low Flow Models / optimized to be operated between $0.016 * Q_{max}$ and $0.48 * Q_{max}$

$0.48 * Q_{max}$ (1:1)	8000	17636	0.15
$0.032 * Q_{max}$ (10:1)	800	1764	0.20
$0.016 * Q_{max}$ (20:1)	400	881	~ 0.50 ^(*)

~ 0.1 (0.7)	~ 0.1 (1.3)	0.2 (3)
~ 0 (0)	~ 0 (0)	~ 0 (0)
~ 0 (0)	~ 0 (0)	~ 0 (0)

^(*) around 0.30 - 0.70 % accuracy depending on the installation conditions

3) Gold Line Models / application fine tuned meters

$1 * Q_{nom}$ (1:1)	23000	50706	0.10
$0.335 * Q_{nom}$ (3:1)	7700	16975	0.12
$0.167 * Q_{nom}$ (6:1)	3850	8487	0.15

0.4 (5.6)	0.6 (9.1)	0.8 (12)
~ 0.1 (0.7)	~ 0.1 (1.2)	0.2 (3)
~ 0 (0.2)	~ 0 (0.4)	0.1 (2)

Repeatability

better $\pm 0.05\%$ of rate

Density

better than ± 0.0015 g/cc - Gold Line: Field adjustable to better ± 0.001 g/cc

Temperature

better $\pm 1^\circ\text{C}$

Standard Models

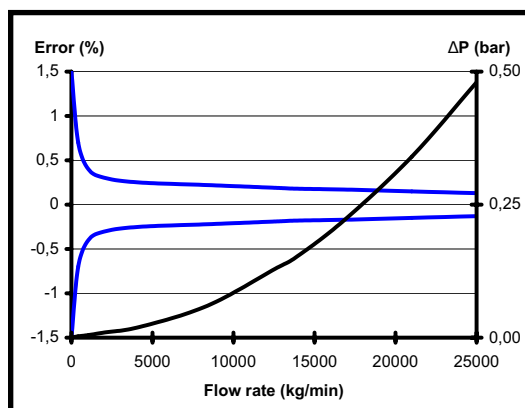

Gold Line Models

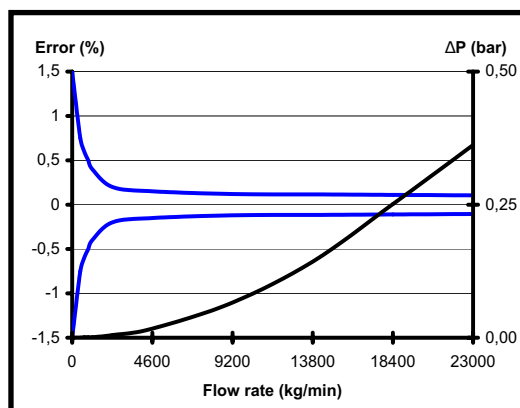

Error of reading (including zero drift) indications refer to reference conditions H_2O , $18-24^\circ\text{C}$ ($66-76^\circ\text{F}$), 1-3 bar (15-45 psi).
 RHM sensor do not suffer from pressure effect due to torsional oscillation and semi circle (non-deforming) measurement section.
 Temperature changes of $\pm 25^\circ\text{C}$ around the operating point are negligible.
 Pressure drop refers to Newton liquids, with parallel measuring loops and block/manifold connection.
 Nominal flow refers to approx. 10 m/s (33 ft/sec) velocity in measuring loops for best performance.
Calibration to customer range, with increased accuracy, possible.

GENERAL DIMENSIONS RHM 160

Type II (sealless welded parallel measuring loops w/o sealings [PF0])

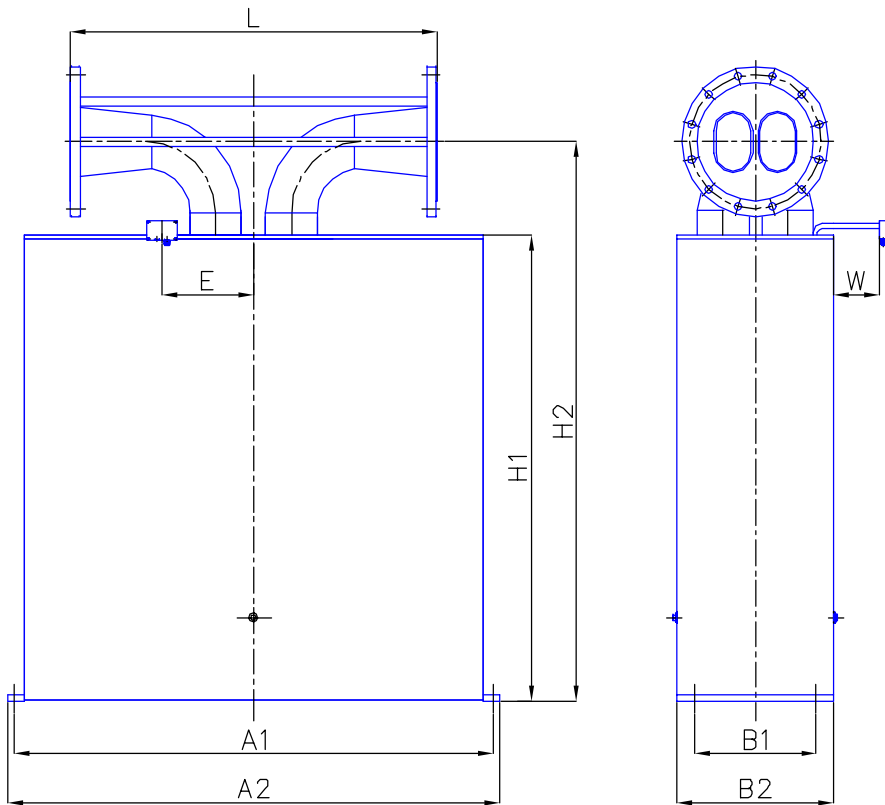

A1 = 1570 mm (61.96")
A1 = 1610 mm (63.38")
B1 = 400 mm (15.74")
B2 = 520 mm (20.47")
H1 = 1505 mm (59.25")
H2 = 1735 mm (68.30")
E = 300 mm (11.82")
W = 150 mm (5.91")

- Weight:
approx. 670 kg (1480 lb)
- Shipping box:
approx. 240 x 190 x 120 cm
(94.5 x 74.8 x 47.3 inch)

	Process Connection	Face to face length (L) ^(*)	Order Code
Standard	10" CL 150 acc. ANSI B16.5	900 mm (35.43")	A3
	10" CL 300 acc. ANSI B16.5	900 mm (35.43")	A4
	12" CL 150 acc. ANSI B16.5	1200 mm (47.24")	A1
	12" CL 300 acc. ANSI B16.5	1200 mm (47.24")	A2
	DN300 / PN16 acc. DIN 2527 - C	1200 mm (47.24")	D1
	DN300 / PN16 acc. DIN 2527 - C	1200 mm (47.24")	D2

(*) Customization possible on request.

The finish type of our ANSI flanges is RF/SF (AARH 125-250 (µinch) - Ra 3,2 up to 6,3 (µm)). Others available on request.

Above table only shows our general process fittings.

For further customization with regard to special fittings and face to face length please contact your local agent.

GENERAL SPECIFICATIONS RHM 160

Approvals

- ATEX (CESI 02 ATEX 053 X):
Ex II 1 G, EEx ia IIC T6-T1
- CSA (220705)
Class I, Div 1 and 2,
Groups A, B, C and D; Type 3
- Custody Transfer Approvals
(PTB 1.32-97027224 and NMI TC 3382)
- PED according to directive 97/23/EC
available

Electrical connection

- Junction box / aluminium coated (standard)
IP 65 (Nema 4X)
(Junction box in SS optional)
- Cable entry M25 x 1.5
(M20 x 1.5, 1/2" and 3/4" NPT optional)
- Max cable length between RHM and RHE:
100 m (330 ft)
200 m (660 ft) only with factory approval

Housing

- Stainless Steel: 1.4301 / SS 304
- others on request -
- Protection class: IP 65 (Nema 4X)
- higher on request -

Material of wetted parts

- 1.4571 / SS 316Ti (standard)
- Other material on request

Pressure rating

- Pressured part of the meter consists of the
measuring loops and the connection part.
The weaker of both parts decides the maximum
allowed operating pressure.
Below is the max. operating pressure of the
measuring loops^(*).

(*) These values are only valid for SS 316Ti & SS 904L materials.
Statements for others materials on request.

Standard version:

60 bar @ 120°C (1450 psi @ 248°F)
wall thickness is generally 5.00 mm (0.19")

Other pressure rating

- on request -

Temperature rating

- NT Models from -20 to +120°C (-4 to +248°F)
- ET Models from -45 to +120°C (-49 to +248°F)
- Special Range on request



For further information
please contact your
local representative

- to be continued with the order code on the next page -

www.rheonik.com - the mass flowmeter experts

ORDER CODE RHM 160

Order Code Structure

The order code of the Rheonik Sensors consists of 6 sections (see previous pages / below). Restrictions of combinations may apply. For specials, please comment your needs in plain text / sketches.

Temperature Rating

T1	NT Models (Normal Temperature Models) from -20 to +120°C (-4 to +248°F)
T2	ET Models (Extended Temperature Models) from -45 to +120°C (-49 to +248°F)
TX	Other Temperature Models (on request)

Pressure Rating

P1	Standard pressure version (60 bar @ 120°C / 870 psi @ 248°F) - <i>page 4</i> -
PX	Other pressure version (on request) - <i>page 4</i> -

Construction Type

PF0	Parallel Measuring Loops Seal Less Welded Version - <i>page 3</i> -
XXX	Other construction type on request

Material of Wetted Parts

M1	1.4571 / SS 316Ti
MX	Other material on request

Process Connection

XX	Code available on page 3.
----	---------------------------

Hazardous Area Approvals

NN	Without Ex Approvals
AT	ATEX Approvals (CESI 02 ATEX 053 X) - Ex II 1 G, EEx ia IIC T6-T1
CS	CSA Approvals (220705) - Class 1, Div 1 / Group A, B, C, and D; Type 3

Order Code Example

M160 T1 P1 PF0 M1 A2 AT

T1: NT (Normal Temperature Models) from -20 to +120°C (-49 to +248°F)

P1: Standard pressure version (60 bar @ 120°C / 870 psi @ 248°F)

PF0: Parallel Measuring Loops Seal Less Welded Version

M1: 1.4571 / SS 316 Ti

A2: 12" CL 300 acc. ANSI B16.5

AT: ATEX Approvals (CESI 02 ATEX 053 X)

M160