

RHM 60 - Coriolis Mass Flowmeter for medium flow also suited for high pressure applications

The RHM 60 can measure flow rates up to 180 t/hr with the patented Omega shape meter technology, manufactured by Rheonik, the mass flowmeter experts.



GENERAL

The RHM 60 has been designed for medium flow rates and tough application conditions. Due to the optional heavy duty measuring pipes (up to 250 bar), this meter becomes the first choice in many applications which have medium flow rates with high operating pressure.

This unique design, which offers excellent performance and reliability, has created the most satisfied customers worldwide. Unlike other mass flowmeter manufacturers, Rheonik uses a patented torsion rod swinger with the Omega shape and support bars which results in high accuracy measurement, which is independent of pressure, even at very low flow velocities. The meter also has extremely good repeatability and high stability for critical applications.

APPLICATIONS

- Loading of boats, vessels, rail tank wagons
- High temperatures and other challenging applications
- Highly viscous media (low pressure drop and excellent performance at low flow conditions)

FEATURES

- As heavy duty version available (increased wall thickness of measuring pipes for additional safety - 200 bar)
- Flow Accuracy of 0.1%
- Repeatability better than 0.05%
- Patented torsion swinger
- Customer adaptations possible for application optimized solutions
- Typical measuring ranges from 30 to 3000 kg/min
- EEx Approvals (i.e. ATEX, CSA, ...)
- Custody Transfer Approvals (i.e. PTB, NMI, ...)

ADVANTAGES

- Medium flow rates in combination with high operating pressure
- Patented torsion swinger design assures most stable and drift free measurement
- Increased signal to noise ratio by torsion swinger
- Longest life time and increased safety (low stress in welds and increased wall thickness against abrasion)
- No moving parts, practically no maintenance

PERFORMANCE RHM 60

Max Flow 3000 kg/min (6610 lb/min)

1) Standard Models

Rates / turndown ratio	in kg/min	in lb/min	error in % of reading
nominal rate Q_{nom}	2500	5512	0.20
$0.2 * Q_{max}$ (5:1)	600	1320	0.20
$0.1 * Q_{max}$ (10:1)	300	661	0.20
$0.05 * Q_{max}$ (20:1)	150	330	0.20
$0.02 * Q_{max}$ (50:1)	60	132	0.50

Typical ΔP in bar (psi)		
1 cP	100 cP	1000 cP
0.6 (8.3)	1.2 (18.3)	3.9 (56)
~ 0 (0.6)	0.1 (1.4)	0.9 (13)
~ 0 (0.1)	~ 0.1 (0.7)	0.5 (6)
~ 0 (0)	~ 0 (0.3)	0.2 (3)
~ 0 (0)	~ 0 (0.1)	~ 0.1 (1)

2) Optimized Low Flow Models^(*) / optimized to be operated between $0.0135 * Q_{max}$ and $0.27 * Q_{max}$

$0.27 * Q_{max}$ (1:1)	800	1763	0.12
$0.027 * Q_{max}$ (10:1)	80	176	0.15
$0.0135 * Q_{max}$ (20:1)	40	88	~ 0.50 ^(**)

~ 0.1 (1.0)	~ 0.2 (2.0)	1.2 (17)
~ 0 (0)	~ 0 (0.2)	0.1 (2)
~ 0 (0)	~ 0 (0.1)	~ 0.1 (1)

^(*) serial/single path version offers the same accuracy at half the flow ($Q_{max} = 1500$ kg/min)

^(**) around 0.30 - 0.70 % accuracy depending on the installation conditions

3) Gold Line Models / application fine tuned meters

$1 * Q_{nom}$ (1:1)	2500	5512	0.10
$0.2 * Q_{nom}$ (5:1)	500	1102	0.12
$0.1 * Q_{nom}$ (10:1)	250	551	0.15

0.6 (8.3)	1.2 (18.3)	3.9 (56)
~ 0 (0.4)	~ 0.1 (1.2)	0.8 (11)
~ 0 (0.1)	~ 0 (0.6)	0.4 (5)

Repeatability

better $\pm 0.05\%$ of rate

Density

better than ± 0.0015 g/cc - Gold Line: Field adjustable to better ± 0.001 g/cc

Temperature

better $\pm 1^\circ\text{C}$

Standard Models

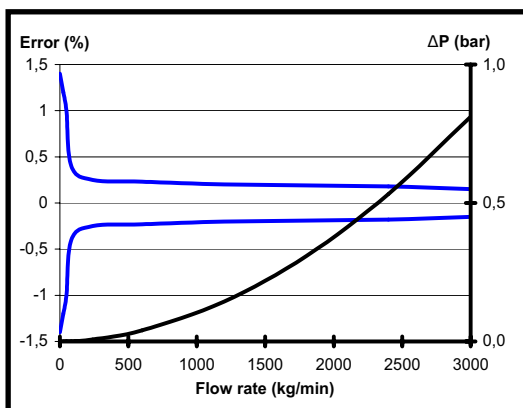

Gold Line Models

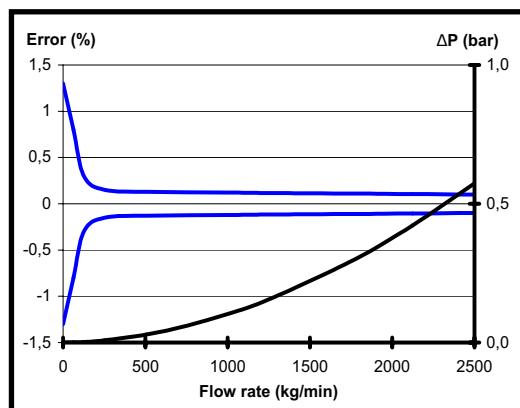

For serial (single pipe/path) sanitary design Q_{max} is 1500 kg/min (50%). Data above refer to standard wall thickness. Error of reading (including zero drift) indications refer to reference conditions H_2O , 18-24°C (66-76°F), 1-3 bar (15-45 psi). RHM sensor do not suffer from pressure effect due to torsional oscillation and semi circle (non-deforming) measurement section. Temperature changes of $\pm 25^\circ\text{C}$ around the operating point are negligible. Pressure drop refers to Newton liquids, with parallel measuring loops and block/manifold connection. Nominal flow refers to approx. 10 m/s (33 ft/sec) velocity in measuring loops for best performance. **Calibration to customer range, with increased accuracy, possible.**

www.rheonik.com - the mass flowmeter experts

GENERAL DIMENSIONS RHM 60

Type II (sealless welded parallel measuring loops w/o sealings [PF0])

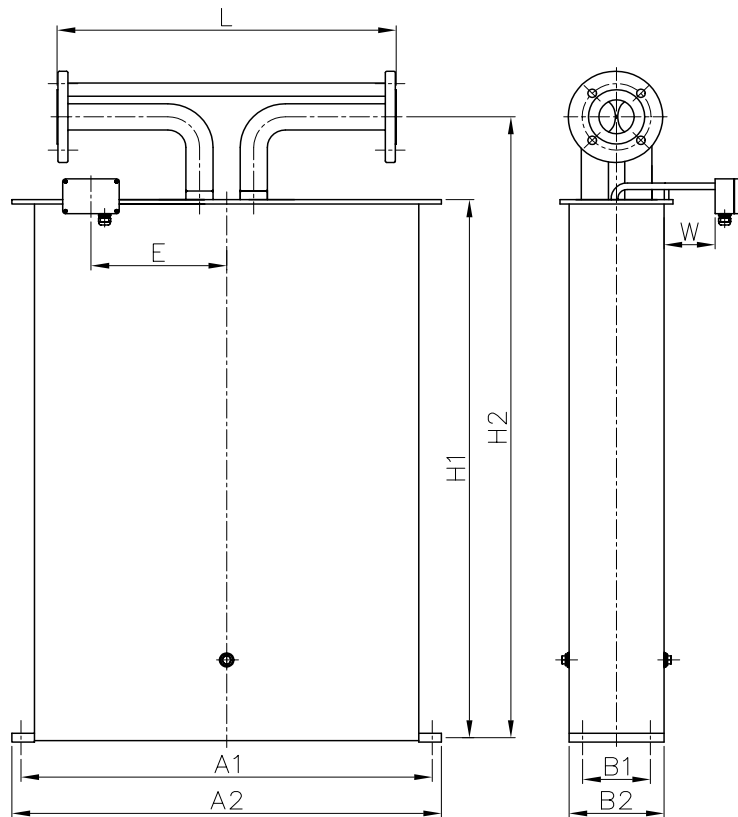

A1	=	910 mm (35.83")
A2	=	950 mm (37.40")
B1	=	150 mm (5.91")
B2	=	230 mm (9.06")
H1	=	1253 mm (49.33")
H2	=	1443 mm (56.81")
E	=	300 mm (11.81")
W	=	150 mm (5.91")

- Weight:
approx. 200 kg (440 lb)
- Shipping box:
approx. 180 x 120 x 75 cm
(71 x 48 x 30 inch)

Process Connection		Face to face length (L) ^(*)	Order Code
Standard	4" CL 150 acc. ANSI B16.5	725 mm (28.54")	F1
	4" CL 300 acc. ANSI B16.5	725 mm (28.54")	F2
	4" CL 600 acc. ANSI B16.5	725 mm (28.54")	F3
	DN100 / PN40 acc. DIN 2527 - C	725 mm (28.54")	C1
	DN100 / PN100 acc. DIN 2527 - E	725 mm (28.54")	C2
Optional	4" CL 900 acc. ANSI B16.5	900 mm (35.43")	A9
	4" CL 1500 acc. ANSI B16.5	900 mm (35.43")	XX
	DN100 / PN160 acc. DIN 2527 - E	900 mm (35.43")	D3
Special	DN100 / PN250 acc. DIN 2527 - E	900 mm (35.43")	XX
	Different sized flanges	please consult factory	XX

(*) Customization possible on request.
 The finish type of our ANSI flanges is RF/SF (AARH 125-250 (µinch) - Ra 3,2 up to 6,3 (µm)). Others available on request.
 Above table only shows our general process fittings.
 For further customization with regard to special fittings and face to face length please contact your local agent.

GENERAL DIMENSIONS RHM 60

Type III (sealless welded serial measuring loops w/o sealings [SF0])

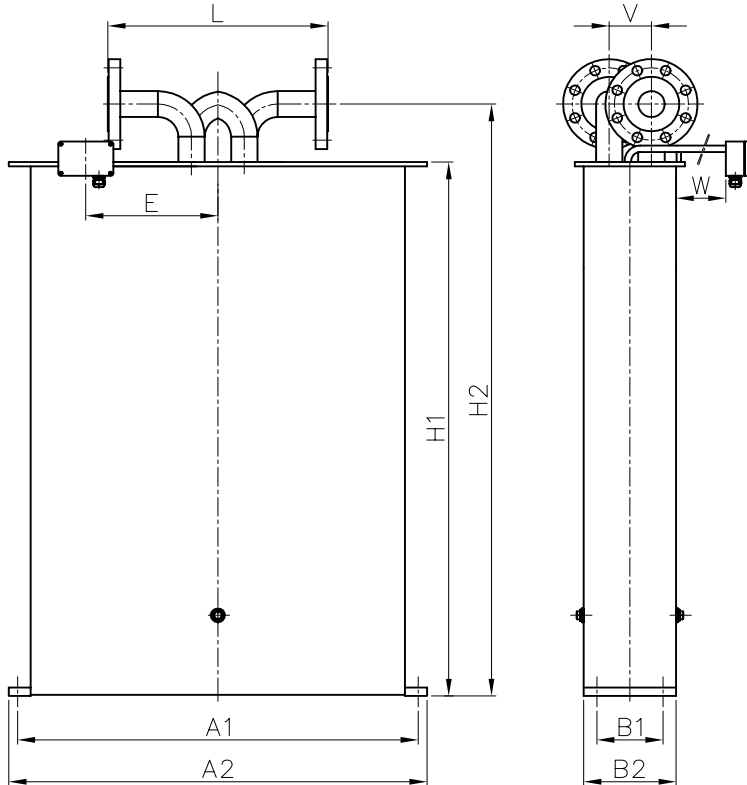

A1 =	910 mm (35.83")
A2 =	950 mm (37.40")
B1 =	150 mm (5.91")
B2 =	230 mm (9.06")
H1 =	1250 mm (49.21")
H2 =	1385 mm (54.53")
E =	300 mm (11.81")
W =	150 mm (5.91")
V =	96 mm (3.78")

- Weight:
approx. 200 kg (440 lb)

- Shipping box:
approx. 180 x 120 x 75 cm
(71 x 48 x 30 inch)

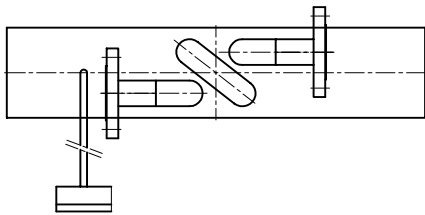

	Process Connection	Face to face length (L) ^(*)	Order Code
Sanitary Fittings ^(**)	2" Tri Clamp acc. DIN 32676	500 mm (19.68")	S1
	DN50 / Sanitary acc. DIN 11851	400 mm (15.74")	S2
Flange Other Fittings	3" CL 150 acc. ANSI B16.5	400 mm (15.75")	A1
	3" CL 300 acc. ANSI B16.5	400 mm (15.75")	A2
	DN80 / PN40 acc. DIN 2527 - C	400 mm (15.75")	D1
	Different sized flanges	please consult factory	XX

^(*) Customization possible on request.

^(**) Fitting material is 1.4435 / SS 316L.

The finish type of our ANSI flanges is RF/SF (AARH 125-250 (µinch) - Ra 3,2 up to 6,3 (µm)). Others available on request.

Above table only shows our general process fittings.

For further customization with regard to special fittings and face to face length please contact your local agent.

GENERAL SPECIFICATIONS RHM 60

Approvals

- ATEX (CESI 02 ATEX 053 X):
Ex II 1 G, EEx ia IIC T6-T1
- CSA (220705)
Class I, Div 1 and 2,
Groups A, B, C and D; Type 3
- Custody Transfer Approvals
(PTB 1.32-97027224 and NMI TC 3382)
- PED according to directive 97/23/EC
available
- 3A Sanitary Approvals

Electrical connection

- Junction box / aluminium coated (standard)
IP 65 (Nema 4X)
(Junction box in SS optional)
- Cable entry M25 x 1.5
(M20 x 1.5, ½" and ¾" NPT optional)
- Max cable length between RHM and RHE:
100 m (330 ft)
200 m (660 ft) only with factory approval

Housing

- Stainless Steel: 1.4301 / SS 304
- others on request -
- Protection class: IP 65 (Nema 4X)
- higher on request -

Material of wetted parts

- 1.4571 / SS 316Ti (standard)
- 1.4539 / SS 904L on request
- Hastelloy C22 on request
- Other material on request

Pressure rating

- Pressured part of the meter consists of the measuring loops and the connection part. The weaker of both parts decides the maximum allowed operating pressure. Below is the max. operating pressure of the measuring loops^(*).

(*) These values are only valid for SS 316Ti & SS 904L materials. Statements for others materials on request.

Standard version:

- 100 bar @ 120°C (1450 psi @ 248°F)
- 90 bar @ 210°C (1305 psi @ 410°F)
- 80 bar @ 350°C (1160 psi @ 662°F)
- wall thickness is generally 2.9 mm (0.11")

Optional high pressure version:

- 200 bar @ 120°C (2900 psi @ 248°F)
- wall thickness is generally 5.5 mm (0.21")

Other pressure version - on request -

Temperature rating

- NT Models from -20 to +120°C (-4 to +248°F)
- ET Models from -45 to +120°C (-49 to +248°F)
- ET1 Models from -200 to +50°C (-328 to +122°F)
- ET2 Models from -45 to +210°C (-49 to +410°C)
- HT Models from 0 to +350°C (+32 to +662°F)



- to be continued with the order code on the next page -

www.rheonik.com - the mass flowmeter experts

ORDER CODE RHM 60

Order Code Structure

The order code of the Rheonik Sensors consists of 6 sections (see previous pages / below). Restrictions of combinations may apply. For specials, please comment your needs in plain text / sketches.

Temperature Rating

T1	NT Models (Normal Temperature Models) from -20 to +120°C (-4 to +248°F)
TA	ET Models (Extended Temperature Models) from -45 to +120°C (-49 to +248°F)
T2	ET2 Models (Extended Temperature Models) from -45 to +210°C (-49 to +410°F)
T3	ET1 Models (Extended Temperature Models) from -200 to +50°C (-328 to +122°F)
T4	HT Models (High Temperature Models) from 0 to +350°C (+32 to +662°F)

Pressure Rating

P1	Standard pressure version (100 bar @ 120°C / 1450 psi @ 248°F) - page 5 -
P2	High pressure version (200 bar 120°C / 2900 psi @ 248°F) - page 5 -
PX	Other pressure version (on request) - page 5 -

Construction Type

PF0	Parallel Measuring Loops Seal Less Welded Version - page 3 -
SF0	Serial Measuring Loops Seal Less Welded Version / Single Path - page 4 -
XXX	Other construction type on request

Material of Wetted Parts

M1	1.4571 / SS 316Ti
M2	1.4539 / SS 904L
M3	Hastelloy C22

Process Connection

XX	Code available on pages 3 and 4.
----	----------------------------------

Hazardous Area Approvals

NN	Without Ex Approvals
AT	ATEX Approvals (CESI 02 ATEX 053 X) - Ex II 1 G, EEx ia IIC T6-T1
CS	CSA Approvals (220705) - Class 1, Div 1 / Group A, B, C, and D; Type 3

Order Code Example

M#60 T1 P1 PF0 M1 A1 AT

T1: NT (Normal Temperature Models) from -20 to +120°C (-49 to +248°F)

P1: Standard pressure version (100 bar @ 120°C / 1450 psi @ 248°F)

PF0: Parallel Measuring Loops Seal Less Welded Version

M1: 1.4571 / SS 316 Ti

A1: 4" CL 150 acc. ANSI B 16.5

AT: ATEX Approvals (CESI 02 ATEX 053 X)

M#60