

RHM 30 - Coriolis Mass Flowmeter for medium flow also suited for high pressure applications

The RHM 30 can measure flow rates up to 45 t/hr with pressures up to 400 bar. This model is medium sized with true reliability for a versatile solution, [manufactured by Rheonik](#), the mass flowmeter experts.



GENERAL

The RHM 30 has been designed for medium flow rates and tough application conditions.

Due to the optional heavy duty measuring pipes (up to 400 bar), this meter is suitable for a wide range of flow rates operating at higher pressure.

This unique design, which offers excellent performance and reliability, has created the most satisfied customers worldwide. Unlike other mass flowmeter manufacturers, Rheonik uses a patented torsion rod swinger with the Omega shape and support bars which results in high accuracy measurement, which is independent of pressure, even at very low flow velocities. The meter also has extremely good repeatability and high stability for critical applications.

APPLICATIONS

- Loading of boats, vessels, rail tank wagons
- High temperatures and other challenging applications
- Highly viscous media (low pressure drop and excellent performance at low flow conditions)

FEATURES

- As heavy duty version available (increased wall thickness of measuring pipes for additional safety) - Operating pressure up to 400 bar
- Patented torsion swinger
- Customer adaptations possible for application optimized solutions
- Typical measuring ranges from 5 kg/min to 750 kg/min
- Flow Accuracy of 0.1%
- Repeatability better than 0.05%
- EEx Approvals (i.e. ATEX, CSA, ...)
- Custody Transfer Approvals (i.e. PTB, NMI, ...)

ADVANTAGES

- Medium flow rates in combination with high operating pressure
- Patented torsion swinger design assures most stable and drift free measurement
- Increased signal to noise ratio by torsion swinger
- Longest life time and increased safety (low stress in welds and increased wall thickness against abrasion)
- No moving parts, practically no maintenance

PERFORMANCE RHM 30

Max Flow 750 kg/min (1650 lb/min)

1) Standard Models

Rates / turndown ratio	in kg/min	in lb/min	error in % of reading
nominal rate Q_{nom}	600.00	1322.00	0.20
$0.2 * Q_{max}$ (5:1)	150.00	330.70	0.20
$0.1 * Q_{max}$ (10:1)	75.00	165.35	0.20
$0.05 * Q_{max}$ (20:1)	37.50	82.75	0.20
$0.02 * Q_{max}$ (50:1)	15.00	33.06	0.50

Typical ΔP in bar (psi)		
1 cP	100 cP	1000 cP
0.4 (5.8)	0.6 (8.7)	4.8 (70)
~ 0 (0.4)	0.1 (1.7)	1.2 (17)
~ 0 (0.2)	~ 0.1 (0.9)	0.6 (9)
~ 0 (0)	~ 0 (0.4)	0.3 (4)
~ 0 (0)	~ 0 (0.1)	~ 0.1 (2)

2) Optimized Low Flow Models^(*) / optimized to be operated between $0.0135 * Q_{max}$ and $0.4 * Q_{max}$

$0.4 * Q_{max}$ (1:1)	300.00	661.50	0.15
$0.02 * Q_{max}$ (20:1)	15.00	33.10	0.20
$0.0135 * Q_{max}$ (30:1)	10.00	22.05	~ 0.50 ^(**)

~ 0.1 (1.9)	0.4 (5.4)	3.4 (49)
~ 0 (0)	~ 0 (0.2)	~ 0.1 (3)
~ 0 (0)	~ 0 (0.1)	~ 0.1 (1)

^(*) serial/single path version offers the same accuracy at half the flow ($Q_{max} = 375$ kg/min)

^(**) around 0.30 - 0.70 % accuracy depending on the installation conditions

3) Gold Line Models / application fine tuned meters

$1 * Q_{nom}$ (1:1)	600.00	1322.00	0.10
$0.1 * Q_{nom}$ (10:1)	60.00	132.25	0.12
$0.05 * Q_{nom}$ (20:1)	30.00	66.10	0.15

0.4 (5.8)	0.6 (8.7)	4.8 (70)
~ 0 (0.1)	~ 0.1 (0.7)	0.7 (10)
~ 0 (0)	~ 0 (0.4)	0.4 (5)

Repeatability

better $\pm 0.05\%$ of rate

Density

better than ± 0.0020 g/cc - Gold Line: Field adjustable to better ± 0.001 g/cc

Temperature

better $\pm 1^\circ\text{C}$

Standard Models

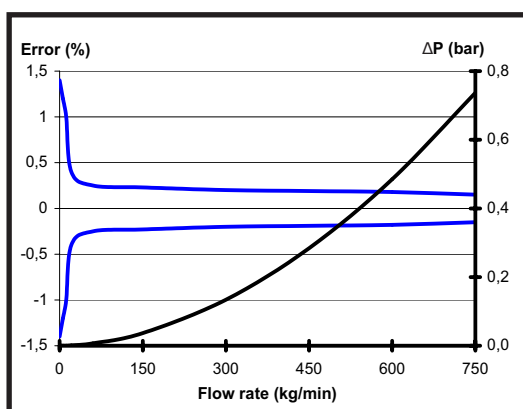

Gold Line Models

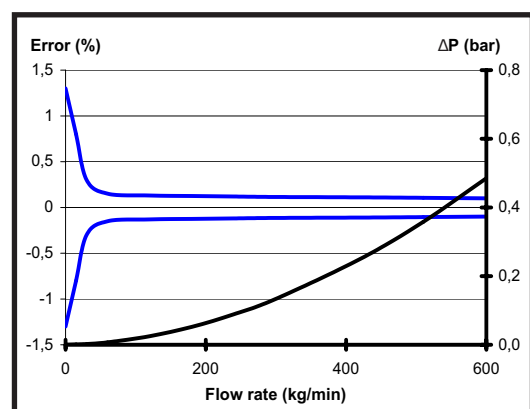

For serial (single pipe/path) sanitary design Q_{max} is 300 kg/min (50%). Data above to standard wall thickness.
 Error of reading (including zero drift) indications refer to reference conditions H_2O , 18-24°C (66-76°F), 1-3 bar (15-45 psi).
 RHM sensor do not suffer from pressure effect due to torsional oscillation and semi circle (non-deforming) measurement section.
 Temperature changes of $\pm 25^\circ\text{C}$ around the operating point are negligible.
 Pressure drop refers to Newton liquids, with parallel measuring loops and block/manifold connection.
 Nominal flow refers to approx. 10 m/s (33 ft/sec) velocity in measuring loops for best performance.
Calibration to customer range, with increased accuracy, possible.

www.rheonik.com - the mass flowmeter experts

GENERAL DIMENSIONS RHM 30

Type I (w/ removable manifold block - parallel / PTFE sealings [PM0])

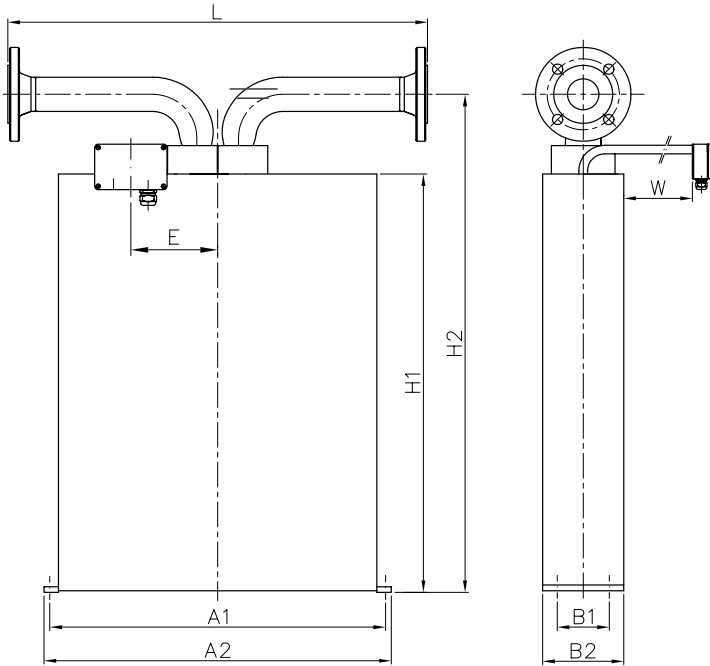

A1 = 580 mm (22.84")
 A2 = 600 mm (23.62")
 B1 = 90 mm (3.54")
 B2 = 140 mm (5.51")
 H1 = 735 mm (28.94")
 H2 = 875 mm (34.45")
 E = 150 mm (5.91")
 W = 150 mm (5.91")

- Weight:
approx. 58 kg (128 lb)
- Shipping box:
approx. 120 x 80 x 80 cm
(47.3 x 31.5 x 31.5 inch)

	Process Connection	Face to face length (L) ^(*)	Order Code
Standard	2" CL 150 acc. ANSI B16.5	725 mm (28.54")	A1
	2" CL 300 acc. ANSI B16.5	725 mm (28.54")	A2
	2" CL 600 acc. ANSI B16.5	725 mm (28.54")	A3
	DN50 / PN40 acc. DIN 2527 - C	725 mm (28.54")	D1
	DN50 / PN100 acc. DIN 2527 - E	725 mm (28.54")	D2
Optional	Different sized flanges	please consult factory	XX

(*) Customization possible on request.

The finish type of our ANSI flanges is RF/SF (AARH 125-250 (µinch) - Ra 3,2 up to 6,3 (µm)). Others available on request.

Above table only shows our general process fittings.

For further customization with regard to special fittings and face to face length please contact your local agent.

GENERAL DIMENSIONS RHM 30

Type II (sealless welded, parallel measuring loops w/o sealings [PF0])

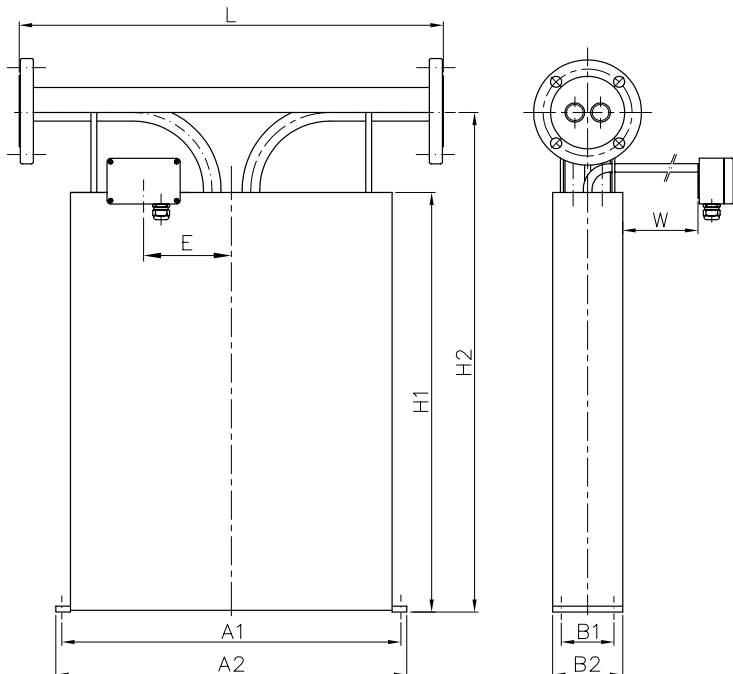

A1	= 580 mm (22.84")
A2	= 600 mm (23.62")
B1	= 90 mm (3.54")
B2	= 140 mm (5.51")
H1	= 735 mm (28.94")
H2	= 875 mm (34.45")
E	= 150 mm (5.91")
W	= 150 mm (5.91")

- Weight:
approx. 58 kg (128 lb)
- Shipping box:
approx. 120 x 80 x 80 cm
(47.3 x 31.5 x 31.5 inch)

	Process Connection	Face to face length (L) ^(*)	Order Code
Standard	3" CL 150 acc. ANSI B16.5	725 mm (28.54")	F1
	3" CL 300 acc. ANSI B16.5	725 mm (28.54")	F2
	3" CL 600 acc. ANSI B16.5	725 mm (28.54")	F3
	DN80 / PN40 acc. DIN 2527 - C	725 mm (28.54")	C1
	DN80 / PN100 acc. DIN 2527 - E	725 mm (28.54")	C2
Optional	3" CL 900 acc. ANSI B16.5	725 mm (28.54")	A5
	3" CL 1500 acc. ANSI B16.5	725 mm (28.54")	A6
	3" CL 2500 acc. ANSI B16.5	725 mm (28.54")	XX
	DN80 / PN160 acc. DIN 2527 - E	725 mm (28.54")	C5
Special	DN80 / PN250 acc. DIN 2527 - E	725 mm (28.54")	XX
	DN80 / PN320 acc. DIN 2527 - E	725 mm (28.54")	XX
	Different sized flanges	please consult factory	XX

(*) Customization possible on request.

The finish type of our ANSI flanges is RF/SF (AARH 125-250 (µinch) - Ra 3,2 up to 6,3 (µm)). Others available on request.

Above table only shows our general process fittings.

For further customization with regard to special fittings and face to face length please contact your local agent.

GENERAL DIMENSIONS RHM 30

Type III (sealless welded serial measuring loops w/o sealings / [SF0])

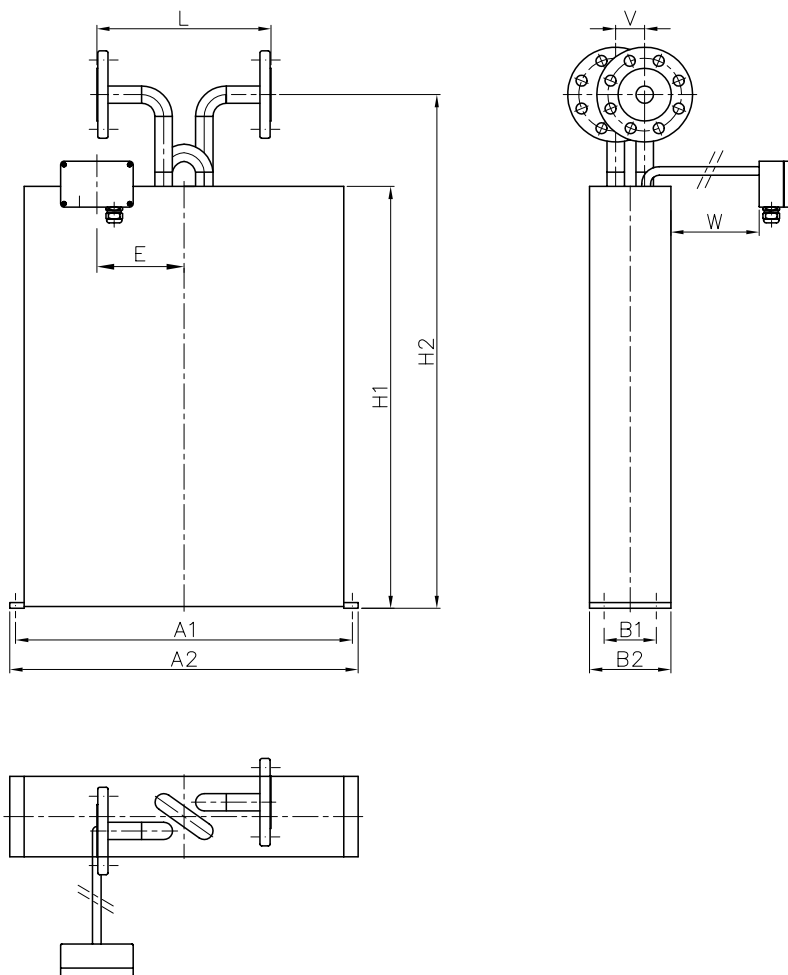

A1 =	580 mm (22.84")
A2 =	600 mm (23.62")
B1 =	90 mm (3.54")
B2 =	140 mm (5.51")
H1 =	735 mm (28.94")
H2 =	875 mm (34.45")
E =	150 mm (5.91")
W =	150 mm (5.91")
V =	50 mm (1.97")

- Weight:
approx. 55 kg (121 lb)
- Shipping box:
approx. 120 x 80 x 80 cm
(47.3 x 31.5 x 31.5 inch)

	Process Connection	Face to face length (L) ^(*)	Order Code
Sanitary Fittings ^(**)	1 ½" Tri Clamp acc. DIN 32676	300 mm (11.82")	S1
	DN32 / Sanitary acc. DIN 11851	300 mm (11.82")	S2
Flange Other Fittings	3" CL 150 acc. ANSI B16.5	300 mm (11.82")	F1
	3" CL 300 acc. ANSI B16.5	300 mm (11.82")	F2
	DN80 / PN40 acc. DIN 2527 - C	300 mm (11.82")	C1
	2" CL 150 acc. ANSI B16.5	300 mm (11.82")	A1
	2" CL 300 acc. ANSI B16.5	300 mm (11.82")	A2
	DN50 / PN40 acc. DIN 2527 - C	300 mm (11.82")	D1
	Different sized flanges	please consult factory	XX

^(*) Customization possible on request.

^(**) Fitting material is 1.4435 / SS 316L.

The finish type of our ANSI flanges is RF/SF (AARH 125-250 (µinch) - Ra 3,2 up to 6,3 (µm)). Others available on request.

Above table only shows our general process fittings.

For further customization with regard to special fittings and face to face length please contact your local agent.

GENERAL SPECIFICATIONS RHM 30

Approvals

- ATEX (CESI 02 ATEX 053 X):
Ex II 1 G, EEx ia IIC T6-T1
- CSA (220705)
Class I, Div 1 and 2,
Groups A, B, C and D; Type 3
- Custody Transfer Approvals
(PTB 1.32-97027224 and NMI TC 3382)
- PED according to directive 97/23/EC
available
- 3A Sanitary Approvals

Electrical connection

- Junction box / aluminium coated (standard)
IP 65 (Nema 4X)
(Junction box in SS optional)
- Cable entry M25 x 1.5
(M20 x 1.5, 1/2" and 3/4" NPT optional)
- Max cable length between RHM and RHE:
100 m (330 ft)
200 m (660 ft) only with factory approval

Housing

- Stainless Steel: 1.4301 / SS 304
- others on request -
- Protection class: IP 65 (Nema 4X)
- higher on request -

Material of wetted parts

- 1.4571 / SS 316Ti (standard)
- 1.4539 / SS 904L on request
- Hastelloy C22 on request
- Tantalum on request
- Other material on request

Pressure rating

- Pressured part of the meter consists of the measuring loops and the connection part. The weaker of both parts decides the maximum allowed operating pressure. Below is the max. operating pressure of the measuring loops^(*).

(*) These values are only valid for SS 316Ti & SS 904L materials. Statements for others materials on request.

Standard version:

- 140 bar @ 120°C (2030 psi @ 248°F)
- 120 bar @ 210°C (1740 psi @ 410°F)
- 100 bar @ 350°C (1450 psi @ 662°F)
- wall thickness is generally 2.0 mm (0.08")

Optional high pressure version:

- 300 bar @ 120°C (4350 psi @ 248°F)
- wall thickness is generally 4.55 mm (0.18")

Extremely high pressure version - on request -

Temperature rating

- NT Models from -20 to +120°C (-4 to +248°F)
- ET Models from -45 to +120°C (-49 to +248°F)
- ET1 Models from -200 to +50°C (-328 to +122°F)
- ET2 Models from -45 to +210°C (-49 to +410°C)
- HT Models from 0 to +350°C (+32 to +662°F)

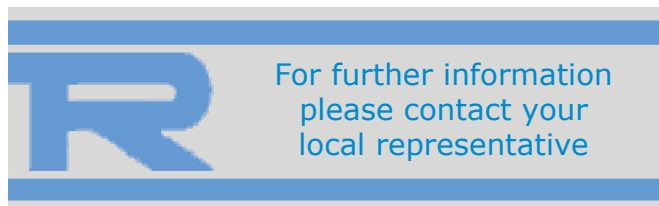

- to be continued with the order code on the next page -

www.rheonik.com - the mass flowmeter experts

ORDER CODE RHM 30

Order Code Structure

The order code of the Rheonik Sensors consists of 6 sections (see previous pages / below). Restrictions of combinations may apply. For specials, please comment your needs in plain text / sketches.

Temperature Rating

T1	NT Models (Normal Temperature Models) from -20 to +120°C (-4 to +248°F)
TA	ET Models (Extended Temperature Models) from -45 to +120°C (-49 to +248°F)
T2	ET2 Models (Extended Temperature Models) from -45 to +210°C (-49 to +410°F)
T3	ET1 Models (Extended Temperature Models) from -200 to +50°C (-328 to +122°F)
T4	HT Models (High Temperature Models) from 0 to +350°C (+32 to +662°F)

Pressure Rating

P1	Standard pressure version (140 bar @ 120°C / 2030 psi @ 248°F) - page 6 -
P2	High pressure version (300 bar 120°C / 4350 psi @ 248°F) - page 6 -
PX	Extremely high pressure version (on request) - page 6 -

Construction Type

PM0	Parallel Measuring Loops with removable Block/Manifold and PTFE Seals - page 3 -
PF0	Parallel Measuring Loops Seal Less Welded Version - page 4 -
SF0	Serial Measuring Loops Seal Less Welded Version / Single Path - page 5 -
XXX	Other construction type on request

Material of Wetted Parts

M1	1.4571 / SS 316Ti
M2	1.4539 / SS 904L
M3	Hastelloy C22
M4	Tantalum

Process Connection

XX	Code available on pages 3, 4 and 5.
----	-------------------------------------

Hazardous Area Approvals

NN	Without Ex Approvals
AT	ATEX Approvals (CESI 02 ATEX 053 X) - Ex II 1 G, EEx ia IIC T6-T1
CS	CSA Approvals (220705) - Class 1, Div 1 / Group A, B, C, and D; Type 3

Order Code Example

M#33 T1 P1 PM0 M1 D1 AT

T1:	NT (Normal Temperature Models) from -20 to +120°C (-49 to +248°F)
P1:	Standard pressure version (140 bar @ 120°C / 2030 psi @ 248°F)
PM0:	Parallel Measuring Loops with removable Block/Manifold and PTFE Seals
M1:	1.4571 / SS 316 Ti
D1:	DIN Flange DN50 / PN40
AT:	ATEX Approvals (CESI 02 ATEX 053 X)

M#33 _ _ _ _ _