

RHM 100 - Coriolis Mass Flowmeter for high Flow Applications

The RHM 100 can measure up to 720 t/hr with the superior and patented Omega shape meter technology [manufactured by rheonik](#), the mass flowmeter experts.



GENERAL

The RHM 100 has been developed due to the increased demand for high throughput coriolis mass flowmeters. This model has been engineered on proven technology and is fast becoming the number one choice for loading and unloading applications.

This unique design, which offers excellent performance and reliability, has created the most satisfied customers worldwide. Unlike other massflowmeter manufacturers, Rheonik uses a patented torsion rod swinger with the Omega shape and support bars which results in high accuracy measurement, which is independent of pressure, even at very low flow velocities. The meter also has extremely good repeatability and high stability for critical applications.

APPLICATIONS

- Loading of boats, vessels, rail road tank wagons
- Any other kind of custody transfer measurement
- Highly viscous media (low pressure drop and excellent performance at low flow conditions)

FEATURES

- As heavy duty version available (increased wall thickness of measuring pipes for additional safety - 220 bar)
- Short face to face length
- Patented Torsion Swinger
- Customer adaptations possible for application optimized solutions
- Typical measuring ranges from 240 to 12.000 kg/min
- Flow Accuracy better than 0.2%
- Repeatability better than 0.05%
- EEx Approvals (i.e. ATEX, CSA, ...)
- Custody Transfer Approvals (i.e. PTB, NMI, ...)

ADVANTAGES

- High flow rates for fast filling
- Patented torsion swinger design assures most stable and drift free measurement
- Increased signal to noise ratio by torsion swinger
- Longest life time and increased safety (low stress in welds and increased wall thickness against abrasion)
- No moving parts, practically no maintenance

PERFORMANCE RHM 100

Max Flow 12000 kg/min (26455 lb/min)

1) Standard Models

Rates / turndown ratio	in kg/min	in lb/min	error in % of reading
nominal rate Q_{nom}	10000	22050	0.20
$0.2 * Q_{max}$ (5:1)	2400	5291	0.20
$0.1 * Q_{max}$ (10:1)	1200	2645	0.20
$0.05 * Q_{max}$ (20:1)	600	1322	0.20
$0.02 * Q_{max}$ (50:1)	240	530	0.50

Typical ΔP in bar (psi)		
1 cP	100 cP	1000 cP
0.5 (6.9)	0.9 (12.9)	1.5 (22)
~ 0 (0.4)	0.1 (1.0)	0.3 (5)
~ 0 (0.1)	~ 0 (0.3)	0.2 (2)
~ 0 (0)	~ 0 (0.1)	0.1 (1)
~ 0 (0)	~ 0 (0)	~ 0 (0)

2) Optimized Low Flow Models / optimized to be operated between $0.0165 * Q_{max}$ and $0.33 * Q_{max}$

$0.33 * Q_{max}$ (1:1)	4000	8818	0.15
$0.033 * Q_{max}$ (10:1)	400	882	0.20
$0.0165 * Q_{max}$ (20:1)	200	441	~ 0.50 ^(*)

~ 0.1 (1.2)	0.2 (2.5)	0.6 (8)
~ 0 (0)	~ 0 (0.1)	~ 0.1 (1)
~ 0 (0)	~ 0 (0)	~ 0 (0)

^(*) around 0.30 - 0.70 % accuracy depending on the installation conditions

3) Gold Line Models / application fine tuned meters

$1 * Q_{nom}$ (1:1)	10000	22050	0.10
$0.25 * Q_{nom}$ (4:1)	2500	5511	0.12
$0.125 * Q_{nom}$ (8:1)	1250	2755	0.15

0.5 (6.9)	0.9 (12.9)	1.5 (22)
~ 0 (0.5)	0.1 (1.1)	~ 0.4 (5)
~ 0 (0.1)	~ 0 (0.3)	~ 0.2 (2)

Repeatability

better $\pm 0.05\%$ of rate

Density

better than ± 0.0015 g/cc - Gold Line: Field adjustable to better ± 0.001 g/cc

Temperature

better $\pm 1^\circ\text{C}$

Standard Models

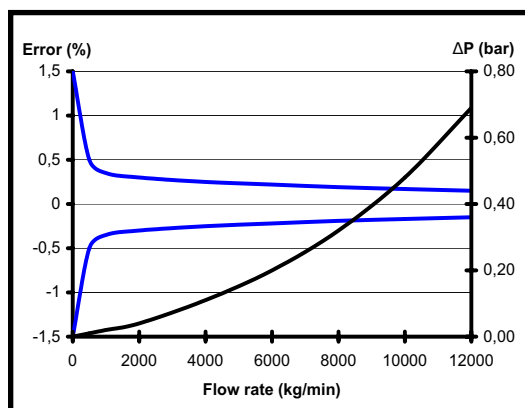

Gold Line Models

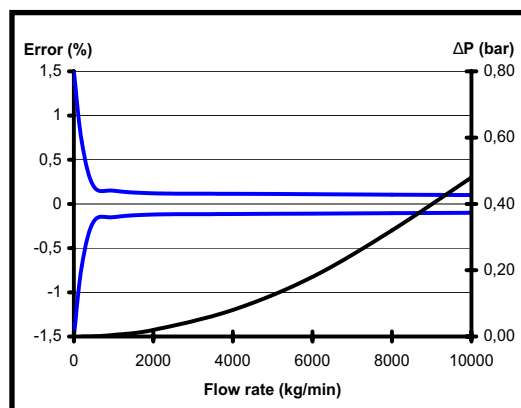

Data above refer to standard wall thickness.

Error of reading (including zero drift) indications refer to reference conditions H_2O , $18-24^\circ\text{C}$ ($66-76^\circ\text{F}$), $1-3$ bar ($15-45$ psi).

RHM sensor do not suffer from pressure effect due to torsional oscillation and semi circle (non-deforming) measurement section.

Temperature changes of $\pm 25^\circ\text{C}$ around the operating point are negligible.

Pressure drop refers to Newton liquids, with parallel measuring loops and block/manifold connection.

Nominal flow refers to approx. 10 m/s (33 ft/sec) velocity in measuring loops for best performance.

Calibration to customer range, with increased accuracy, possible.

GENERAL DIMENSIONS RHM 100

Type II (sealless welded parallel measuring loops w/o sealings [PF0])

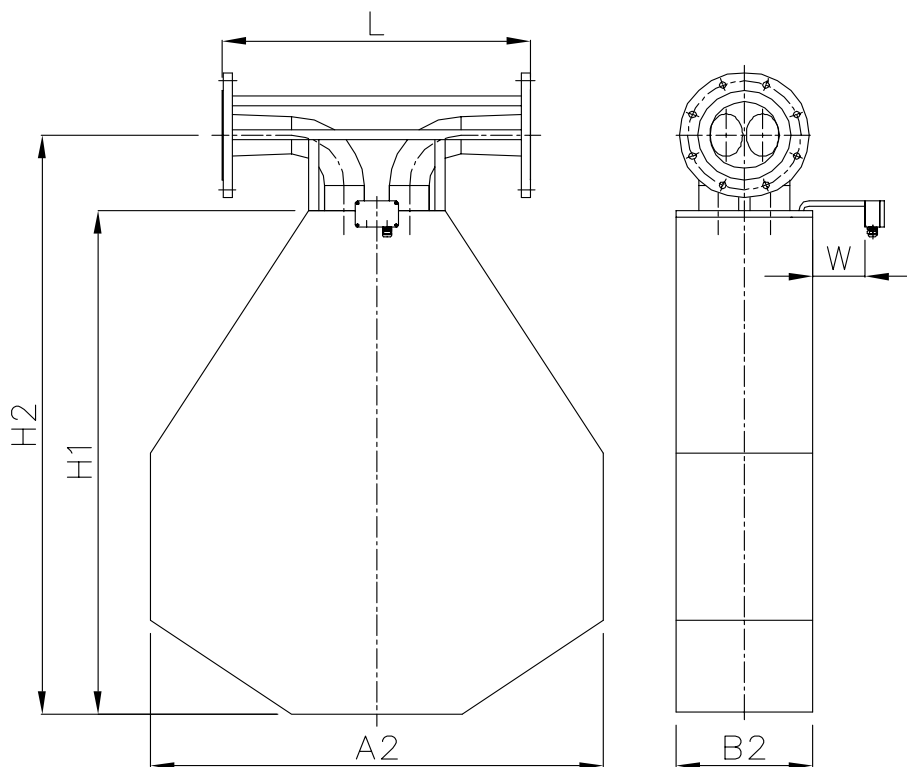

A2 = 1320 mm (51.96")
 B2 = 403 mm (15.86")
 H1 = 1505 mm (59.25")
 H2 = 1735 mm (68.30")
 W = 150 mm (5.91")

- Weight:
approx. 475 kg (1050 lb)
- Shipping box:
approx. 220 x 160 x 90 cm
(87 x 63 x 36 inch)

Process Connection		Face to face length (L) ^(*)	Order Code
Standard	8" CL 150 acc. ANSI B16.5	900 mm (35.43")	A1
	8" CL 300 acc. ANSI B16.5	900 mm (35.43")	A2
	8" CL 600 acc. ANSI B16.5	900 mm (35.43")	A3
	DN200 / PN16 acc. DIN 2527 - C	900 mm (35.43")	D1
	DN200 / PN40 acc. DIN 2527 - C	900 mm (35.43")	D2
Optional	8" CL 900 acc. ANSI B16.5	900 mm (35.43")	A4
	8" CL 1500 acc. ANSI B16.5	900 mm (35.43")	A5
	DN200 / PN100 acc. DIN 2527 - E	900 mm (35.43")	D3

(*) Customization possible on request.

The finish type of our ANSI flanges is RF/SF (AARH 125-250 (µinch) - Ra 3,2 up to 6,3 (µm)). Others available on request.

Above table only shows our general process fittings.

For further customization with regard to special fittings and face to face length please contact your local agent.

GENERAL SPECIFICATIONS RHM 100

Approvals

- ATEX (CESI 02 ATEX 053 X):
Ex II 1 G, EEx ia IIC T6-T1
- CSA (220705)
Class I, Div 1 and 2,
Groups A, B, C and D; Type 3
- Custody Transfer Approvals
(PTB 1.32-97027224 and NMI TC 3382)
- PED according to directive 97/23/EC
available

Electrical connection

- Junction box / aluminium coated (standard)
IP 65 (Nema 4X)
(Junction box in SS optional)
- Cable entry M25 x 1.5
(M20 x 1.5, ½" and ¾" NPT optional)
- Max cable length between RHM and RHE:
100 m (330 ft)
200 m (660 ft) only with factory approval

Housing

- Stainless Steel: 1.4301 / SS 304
- others on request -
- Protection class: IP 65 (Nema 4X)
- higher on request -

Material of wetted parts

- 1.4571 / SS 316Ti (standard)
- 1.4539 / SS 904L on request
- Hastelloy C22 on request
- Other material on request

Pressure rating

- Pressured part of the meter consists of the measuring loops and the connection part. The weaker of both parts decides the maximum allowed operating pressure. Below is the max. operating pressure of the measuring loops^(*).

(*) These values are only valid for SS 316Ti & SS 904L materials. Statements for others materials on request.

• Standard version:

100 bar @ 120°C (1450 psi @ 248°F)
90 bar @ 210°C (1305 psi @ 410°F)
75 bar @ 350°C (1085 psi @ 662°F)
wall thickness is generally 5.40 mm (0.21")

• Optional high pressure version:

220 bar @ 120°C (3190 psi @ 248°F)
wall thickness is generally 11.12 mm (0.44")

• Other pressure rating - on request -

Temperature rating

- NT Models from -20 to +120°C (-4 to +248°F)
- ET Models from -45 to +120°C (-49 to +248°F)
- ET1 Models from -200 to +50°C (-328 to +122°F)
- ET2 Models from -45 to +210°C (-49 to +410°C)
- Higher Temperature Models on request



- to be continued with the order code on the next page -

ORDER CODE RHM 100

Order Code Structure

The order code of the Rheonik Sensors consists of 6 sections (see previous pages / below). Restrictions of combinations may apply. For specials, please comment your needs in plain text / sketches.

Temperature Rating

T1	NT Models (Normal Temperature Models) from -20 to +120°C (-4 to +248°F)
TA	ET Models (Extended Temperature Models) from -45 to +120°C (-49 to +248°F)
T2	ET2 Models (Extended Temperature Models) from -45 to +210°C (-49 to +410°F)
T3	ET1 Models (Extended Temperature Models) from -200 to +50°C (-328 to +122°F)
TX	Other Temperature Models (on request)

Pressure Rating

P1	Standard pressure version (100 bar @ 120°C / 1450 psi @ 248°F) - page 4 -
P2	High pressure version (220 bar 120°C / 3190 psi @ 248°F) - page 4 -
PX	Other pressure version (on request) - page 4 -

Construction Type

PF0	Parallel Measuring Loops Seal Less Welded Version - page 3 -
XXX	Other construction type on request

Material of Wetted Parts

M1	1.4571 / SS 316Ti
M2	1.4539 / SS 904L
M3	Hastelloy C22

Process Connection

XX	Code available on page 3.
----	---------------------------

Hazardous Area Approvals

NN	Without Ex Approvals
AT	ATEX Approvals (CESI 02 ATEX 053 X) - Ex II 1 G, EEx ia IIC T6-T1
CS	CSA Approvals (220705) - Class 1, Div 1 / Group A, B, C, and D; Type 3

Order Code Example

M100 T1 P1 PF0 M1 A2 AT

T1: NT (Normal Temperature Models) from -20 to +120°C (-49 to +248°F)

P1: Standard pressure version (100 bar @ 120°C / 1450 psi @ 248°F)

PF0: Parallel Measuring Loops Seal Less Welded Version

M1: 1.4571 / SS 316 Ti

A2: 8" CL 300 acc. ANSI B 16.5

AT: ATEX Approvals (CESI 02 ATEX 053 X)

M100