

RHM 08 - One of the most popular Rheonik Mass Flowmeter serving thousands of worldwide applications

The RHM 08 can measure flow rates up to 50 kg/min (110 lb/min) with temperatures in excess of 350°C and pressures up to 570 bar. This model has true reliability for a versatile solution, [manufactured by Rheonik](#), the mass flowmeter experts.

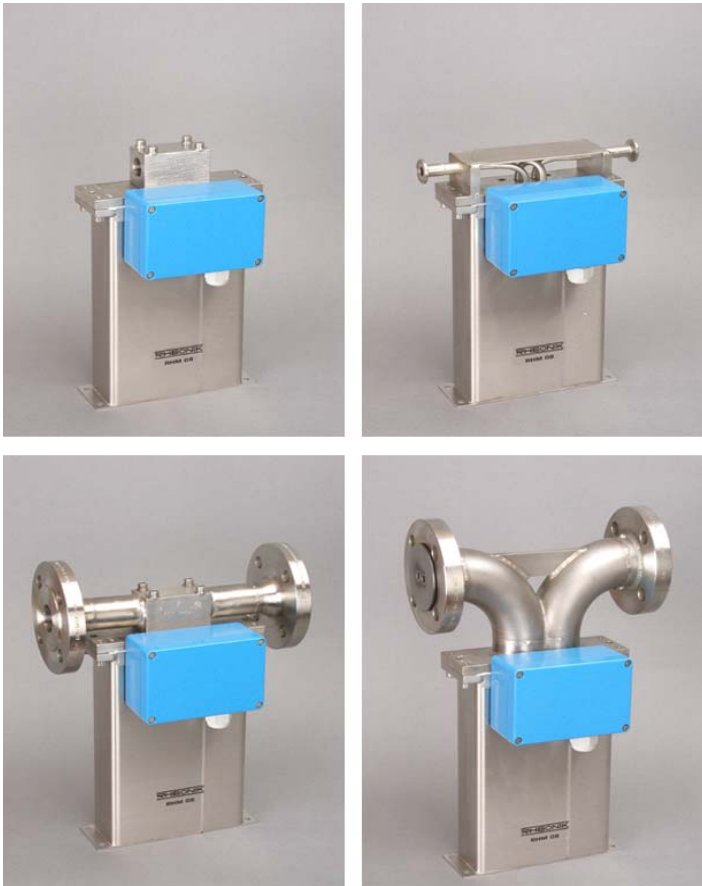

GENERAL

The RHM 08 is one of Rheonik's most popular meters. With flow measurement up to 50 kg/min and the large number of model variants available, this meter is suitable for many applications.

As with all other Rheonik meters, this model is based on the patented Omega design with increased signal to noise ratio.

This unique design, which offers excellent performance and reliability, has created the most satisfied customers worldwide. Unlike other mass flowmeter manufacturers, Rheonik uses a patented torsion rod swinger with the Omega shape and support bars which results in high accuracy measurement, which is independent of pressure, even at very low flow velocities. The meter has also extremely good repeatability and high stability for critical applications.

APPLICATIONS

Suitable for virtually any mass flow application such as:

- Batching
- Dosing
- General flow control
- Injections
- Filling

FEATURES

The outstanding features include:

- Suitable for pressure up to 900 bar
- Typical measuring ranges from 0.5 kg/min to 50 kg/min
- Minimal flows as low as 0.30 kg/min
- Flow Accuracy of 0.10%
- Repeatability better than 0.05%
- Optimised solutions for your batching operation
- Extra compact design with minimal space requirement –ideal for CNG applications–
- EEx Approvals (i.e. ATEX, CSA, ...)
- Custody Transfer Approvals (i.e. PTB, NMI, ...)

ADVANTAGES

- No pressure effect – no deterioration of accuracy due to pressure changes by the patented Omega Shape
- Patented torsion swinger design assures longest life time and increased safety (low stress in welds and increased wall thickness against abrasion)
- No moving parts – practically no maintenance
- Removable connection block

PERFORMANCE RHM 08

Max Flow 50 kg/min (110 lb/min)

1) Standard Models

Rates / turndown ratio	in kg/min	in lb/min	error in % of reading
nominal rate Q_{nom}	50.000	110.25	0.15
$0.2 * Q_{max}$ (5:1)	10.000	22.05	0.20
$0.1 * Q_{max}$ (10:1)	5.000	11.03	0.20
$0.05 * Q_{max}$ (20:1)	2.500	5.51	0.20
$0.02 * Q_{max}$ (50:1)	1.000	2.21	0.50

Typical ΔP in bar (psi)		
1 cP	100 cP	1000 cP
1.2 (16.8)	4.1 (58.8)	37.8 (550)
0.1 (0.9)	0.8 (11.1)	7.5 (109)
~ 0 (0.2)	0.4 (5.5)	3.8 (55)
~ 0 (0.1)	0.2 (2.7)	1.9 (27)
~ 0 (0)	~ 0.1 (1.1)	0.8 (11)

2) Optimized Low Flow Models^(*) / optimized to be operated between $0.012 * Q_{max}$ and $0.4 * Q_{max}$

$0.4 * Q_{max}$ (1:1)	20.000	44.10	0.15
$0.02 * Q_{max}$ (20:1)	1.000	2.21	0.20
$0.012 * Q_{max}$ (30:1)	0.600	1.32	~ 0.50 ^(**)

0.2 (3.2)	1.6 (22.5)	15.1 (219)
~ 0 (0)	~ 0.1 (1.1)	0.8 (11)
~ 0 (0)	~ 0.1 (0.6)	0.5 (6)

^(*) serial/single path version offers the same accuracy at half the flow ($Q_{max} = 25$ kg/min)

^(**) around 0.30 - 0.70 % accuracy depending on the installation conditions

3) Gold Line Models / application fine tuned meters

$1 * Q_{nom}$ (1:1)	50.000	44.10	0.10
$0.1 * Q_{nom}$ (10:1)	5.000	11.03	0.10
$0.05 * Q_{nom}$ (20:1)	2.500	5.51	0.12

1.2 (16.8)	4.1 (58.8)	37.8 (550)
~ 0 (0.2)	0.4 (5.5)	3.8 (55)
~ 0 (0.1)	0.2 (2.7)	1.9 (27)

Repeatability better ± 0.05 % of rate
Temperature better $\pm 1^\circ\text{C}$

Standard Models

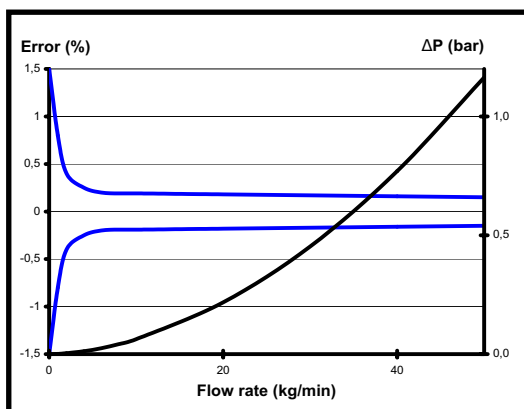

Gold Line Models

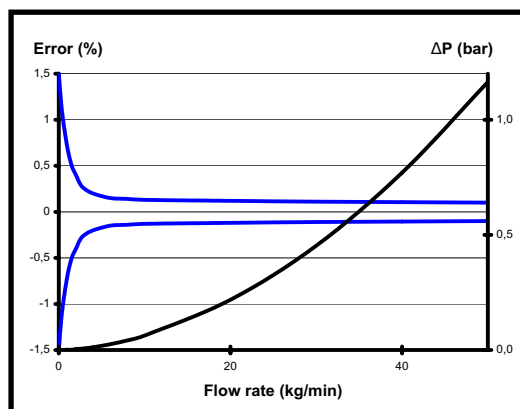

For serial (single pipe/path) sanitary design Q_{max} is 25 kg/min (50%). Data above refer to standard wall thickness.
 Error of reading (including zero drift) indications refer to reference conditions H_2O , $18-24^\circ\text{C}$ ($66-76^\circ\text{F}$), 1-3 bar (15-45 psi).
 RHM sensor do not suffer from pressure effect due to torsional oscillation and semi circle (non-deforming) measurement section.
 Temperature changes of $\pm 25^\circ\text{C}$ around the operating point are negligible.
 Pressure drop refers to Newton liquids, with parallel measuring loops and block/manifold connection.
 Nominal flow refers to approx. 10 m/s (33 ft/sec) velocity in measuring loops for best performance.
Calibration to customer range, with increased accuracy, possible.

GENERAL OUTLINE DIMENSIONS RHM 08

Type I (w/ removable manifold block - serial [SM0] /parallel [PM0] / PTFE seals)

Thread type:

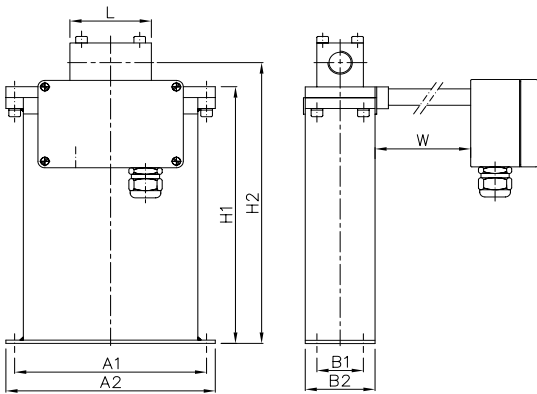

Weight approx. 5kg (11 lb)

A1=165 mm (6.50")
A2=180 mm (7.09")

Flange type:

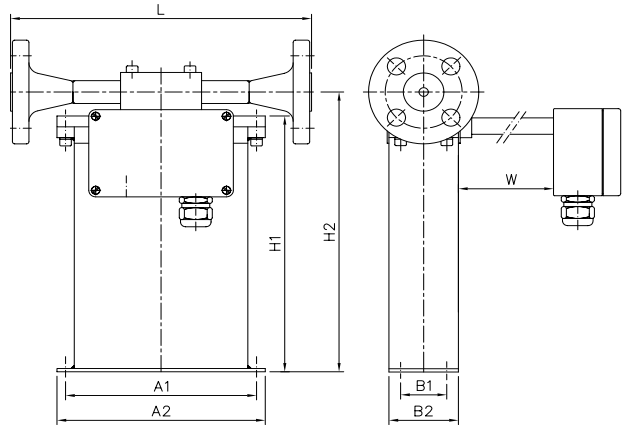

Weight approx. 8kg (18 lb)

B1=40 mm (1.58")
B2=60 mm (2.36")

H1=234 mm (9.21")
H2=255 mm (10.04")

W= 0 mm for standard temperature models -45/-20 to +120°C (-49/-4 to +248°F)
= 150 mm (5.91") for extended (ET1, ET2) and high temperature models^(*)

Process Connection		Face to face length (L) ^(**)	Order Code
Thread Standard	G ½" female	70 mm (2.76")	G1
	NPT ½" female	70 mm (2.76")	N1
Thread Opt.	Autoclave (MP)	100 mm (3.94")	P2

Flange Standard	1" CL 150 acc. ANSI B16.5	260 mm (10.24")	A1
	1" CL 300 acc. ANSI B16.5	260 mm (10.24")	A2
	1" CL 600 acc. ANSI B16.5	300 mm (11.82")	A3
	DN25 / PN40 acc. DIN 2635 - C	260 mm (10.24")	D1
	DN25 / PN100 acc. DIN 2637 - E	300 mm (11.82")	D2
Flange Optional	1" CL 900 / 1500 acc. ANSI B16.5	350 mm (13.78")	A6
	1" CL 2500 acc. ANSI B16.5	350 mm (13.78")	XX
	DN25 / PN160 acc. DIN 2638 - E	300 mm (11.82")	D3
Special	1" JIS flanges	standard - 260 mm (8.67")	XX
	Swagelok	standard - 230 mm (9.06")	XX
	VCR	standard - 230 mm (9.06")	XX
	Novaswiss	standard - 230 mm (9.06")	XX

^(*) For high temperature models (HT) type II or type III are preferred - see next pages.

^(**) Customization possible on request.

Our standard seals are PTFE - Manifold block on request available without seals but with brazed connection block.

The finish type of our ANSI flanges is RF/SF (AARH 125-250 (µinch) - Ra 3,2 up to 6,3 (µm)). Others available on request.

Above table only shows our general process fittings.

For further customization with regard to face to face length and special fittings please contact your local agent.

www.rheonik.com - the mass flowmeter experts

GENERAL OUTLINE DIMENSIONS RHM 08

Type II (sealless welded, parallel measuring loops w/o seals [PF0])

Flange type:

Special fittings:

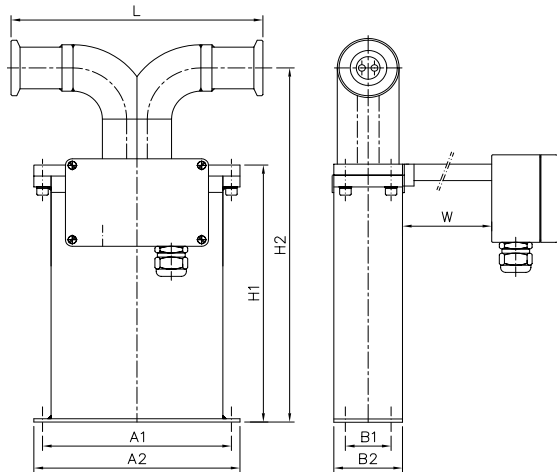
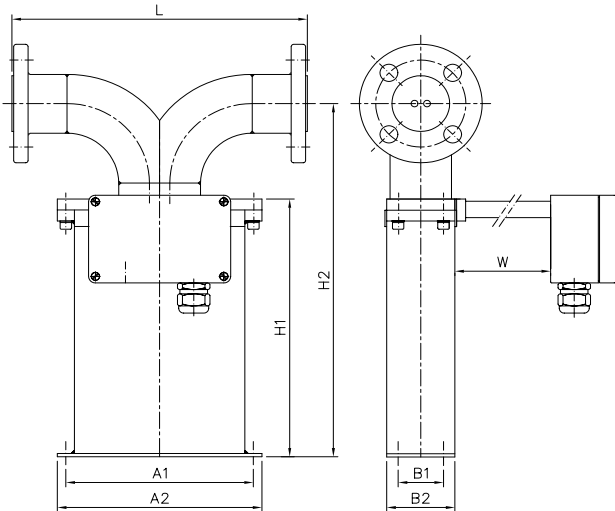

Weight approx. 8kg (18 lb)

Weight approx. 8kg (18 lb)

A1=165 mm (6.50")
A2=180 mm (7.09")

B1=40 mm (1.58")
B2=60 mm (2.36")

H1=234 mm (9.21")
H2=322 mm (12.68")

W= 0 mm for standard temperature models -45/-20 to +120°C (-49/-4 to +248°F)
= 150 mm (5.91") for extended (ET1, ET2) and high temperature models

	Process Connection	Face to face length (L) ^(*)	Order Code
Standard	1" CL 150 acc. ANSI B16.5	260 mm (10.24")	A1
	1" CL 300 acc. ANSI B16.5	260 mm (10.24")	A2
	1" CL 600 acc. ANSI B16.5	300 mm (11.82")	A3
	DN25 / PN40 acc. DIN 2527 - C	260 mm (10.24")	D1
	DN25 / PN100 acc. DIN 2527 - E	300 mm (11.82")	D2
Optional	1" CL 900 / 1500 acc. ANSI B16.5	300 mm (11.82")	A6
	1" CL 2500 acc. ANSI B16.5	300 mm (11.82")	XX
	DN25 / PN160 acc. DIN 2527 - E	300 mm (11.82")	D3
Special	1" JIS flanges	standard - 260 mm (10.24")	XX
	Grayloc or equivalent hubb	standard - 230 mm (9.06")	XX
	Swagelok	standard - 230 mm (9.06")	XX

(*) Customization possible on request.

The finish type of our ANSI flanges is RF/SF (AARH 125-250 (µinch) - Ra 3,2 up to 6,3 (µm)). Others available on request.

Above table only shows our general process fittings.

For further customization with regard to special fittings and face to face length please contact your local agent.

GENERAL OUTLINE DIMENSIONS RHM 08

Type III (sealless welded, serial measuring loops - single path w/o seals [SF0])

Sanitary fittings:

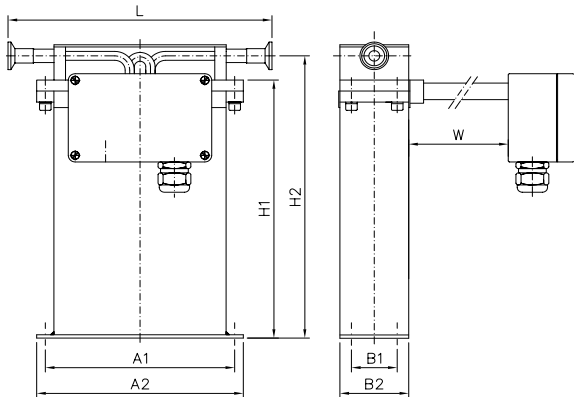

Weight approx. 7 kg (15 lb)

Flange / Other fittings type:

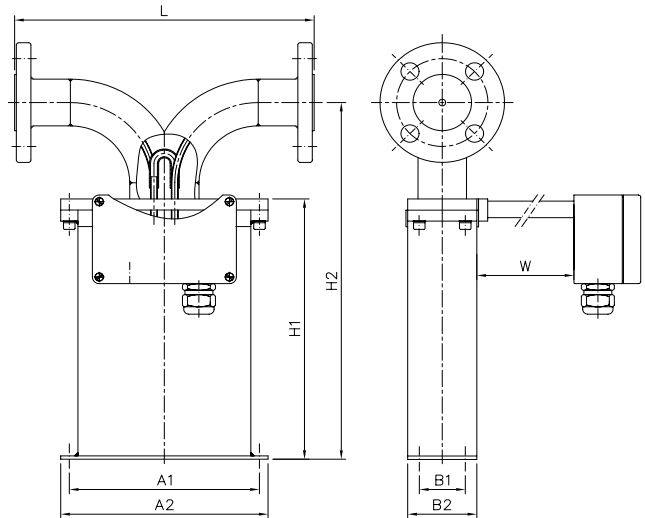

Weight approx. 8 kg (18 lb)

A1=165 mm (6.50")
A2=180 mm (7.09")

B1=40 mm (1.58")
B2=60 mm (2.36")

H1=234 mm (9.21")
H2=255 mm (10.04") for sanitary fittings
H2=322 mm (12.68") for flange type

W= 0 mm for standard temperature models -45/-20 to +120°C (-49/-4 to +248°F)
= 150 mm (5.91") for extended (ET1, ET2) and high temperature models

Process Connection		Face to face length (L) ^(*)	Order Code
Sanitary Fittings ^(**)	½" Tri Clamp acc. DIN 32676	230 mm (9.06")	S1
	DN10 / Sanitary acc. DIN 11851	230 mm (9.06")	S2
	Neumo DN15/PN16	standard - 230 mm (9.06")	XX
Flange Other Fittings	1" CL 150 acc. ANSI B16.5	260 mm (10.24")	A1
	1" CL 300 acc. ANSI B16.5	260 mm (10.24")	A2
	DN25 / PN40 acc. DIN 2527 - C	260 mm (10.24")	D1
	½" CL 150 acc. ANSI B16.5	260 mm (10.24")	XX
	½" CL 300 acc. ANSI B16.5	260 mm (10.24")	XX
	DN15 / PN40 acc. DIN 2527 - C	260 mm (10.24")	XX
	Swagelok	standard - 230 mm (9.06")	XX

(*) Customization possible on request.

(**) Fitting material is 1.4435 / SS 316L.

The finish type of our ANSI flanges is RF/SF (AARH 125-250 (µinch) - Ra 3,2 up to 6,3 (µm)). Others available on request.

Above table only shows our general process fittings.

For further customization with regard to special fittings and face to face length please contact your local agent.

GENERAL SPECIFICATIONS RHM 08

Approvals

- ATEX (CESI 02 ATEX 053 X):
Ex II 1 G, EEx ia IIC T6-T1
- CSA (220705)
Class I, Div 1 and 2,
Groups A, B, C and D; Type 3
- Custody Transfer Approvals
(PTB 1.32-97027224 and NMI TC 3382)
- PED according to directive 97/23/EC
available
- 3A Sanitary Approvals

Electrical connection

- Junction box / aluminium coated (standard)
IP 65 (Nema 4X)
(Junction box in SS optional)
- Cable entry M25 x 1.5
(M20 x 1.5, 1/2" and 3/4" NPT optional)
- Max cable length between RHM and RHE:
100 m (330 ft)
200 m (660 ft) only with factory approval

Housing

- Stainless Steel: 1.4301 / SS 304
- others on request -
- Protection class: IP 65 (Nema 4X)
- higher on request -

Material of wetted parts

- 1.4571 / SS 316Ti (standard)
- 1.4539 / SS 904L on request
- Hastelloy C22 on request
- Tantalum on request
- Other material on request

Pressure rating

- Pressured part of the meter consists of the measuring loops and the connection part. The weaker of both parts decides the maximum allowed operating pressure. Below is the max. operating pressure of the measuring loops^(*).

(*) These values are only valid for SS 316Ti & SS 904L materials. Statements for others materials on request.

Standard version:

- 290 bar @ 120°C (4205 psi @ 248°F)
- 220 bar @ 210°C (3190 psi @ 410°F)
- 200 bar @ 350°C (2900 psi @ 662°F)
- wall thickness is generally 1.0 mm (0.04")

Optional low pressure loss version:

- 140 bar @ 120°C (2030 psi @ 248°F)
- wall thickness is generally 0.5 mm (0.02")

Optional high pressure version:

- 540 bar @ 120°C (7830 psi @ 248°F)
- wall thickness is generally 2.0 mm (0.08")

Extremely high pressure (special material)

- 900 bar @ 120°C (7830 psi @ 248°F)
- wall thickness is generally 1.6 mm (0.06")

Temperature rating

- NT Models from -20 to +120°C (-4 to +248°F)
- ET Models from -45 to +120°C (-49 to +248°F)
- ET1 Models from -200 to +50°C (-328 to +122°F)
- ET2 Models from -45 to +210°C (-49 to +410°C)
- HT Models from 0 to +350°C (+32 to +662°F)



- to be continued with the order code on the next page -

www.rheonik.com - the mass flowmeter experts

ORDER CODE RHM 08

Order Code Structure

The order code of the Rheonik Sensors consists of 6 sections (see previous pages / below). Restrictions of combinations may apply. For specials, please comment your needs in plain text / sketches.

Temperature Rating

T1	NT Models (Normal Temperature Models) from -20 to +120°C (-4 to +248°F)
TA	ET Models (Extended Temperature Models) from -45 to +120°C (-49 to +248°F)
T2	ET2 Models (Extended Temperature Models) from -45 to +210°C (-49 to +410°F)
T3	ET1 Models (Extended Temperature Models) from -200 to +50°C (-328 to +122°F)
T4	HT Models (High Temperature Models) from 0 to +350°C (+32 to +662°F)

Pressure Rating

P0	Low pressure loss version (140 bar @ 120°C / 2030 psi @ 248°F) - page 6 -
P1	Standard pressure version (290 bar 120°C / 4205 psi @ 248°F) - page 6 -
PX	Extremely high pressure version (on request) - page 6 -

Construction Type

PM0	Parallel Measuring Loops with removable Block/Manifold and PTFE Seals - page 3 -
SM0	Serial Measuring Loops with removable Block/Manifold and PTFE Seals - page 3 -
PFO	Parallel Measuring Loops Seal Less Welded Version - page 4 -
SFO	Serial Measuring Loops Seal Less Welded Version / Single Path - page 5 -
XXX	Other construction type on request

Material of Wetted Parts

M1	1.4571 / SS 316Ti
M2	1.4539 / SS 904L
M3	Hastelloy C22
M4	Tantalum

Process Connection

XX	Code available on pages 3, 4 and 5.
----	-------------------------------------

Hazardous Area Approvals

NN	Without Ex Approvals
AT	ATEX Approvals (CESI 02 ATEX 053 X) - Ex II 1 G, EEx ia IIC T6-T1
CS	CSA Approvals (220705) - Class 1, Div 1 / Group A, B, C, and D; Type 3

Order Code Example

M#08 T1 P1 PM0 M1 G1 AT

T1:	NT (Normal Temperature Models) from -20 to +120°C (-49 to +248°F)
P1:	Standard pressure version (290 bar @ 120°C / 4205 psi @ 248°F)
PM0:	Parallel Measuring Loops with removable Block/Manifold and PTFE Seals
M1:	1.4571 / SS 316 Ti
G1:	Female Thread G 1/2"
AT:	ATEX Approvals (CESI 02 ATEX 053 X)

M#08

www.rheonik.com - the mass flowmeter experts