

## RHM 015 - Ultimate Low Flow Coriolis Mass Flowmeter

The RHM 015 can reliably measure flow rates as low as 1 g/min (0.002 lb/min). With its extremely wide turn-down ratio of 300 to 1, this model is perfect for laboratory and test applications. A true low flow mass flowmeter **manufactured by Rheonik**, the mass flowmeter experts.

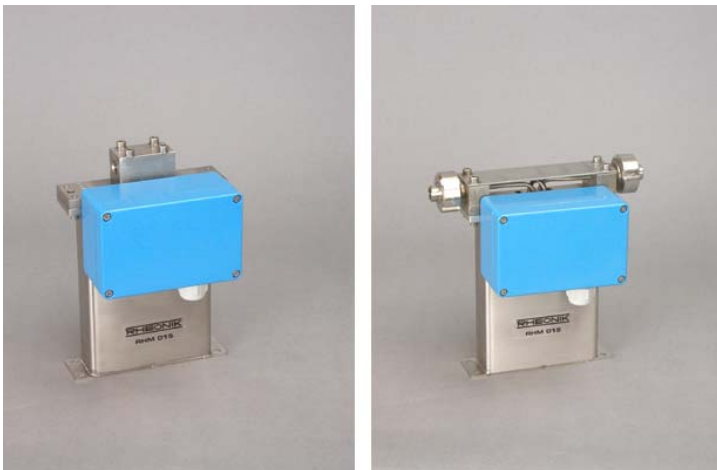

### **GENERAL**

The RHM 015 has been in production for many years and is available in a wide range of varying models. The meter has been optimized for applications which have extremely low flow rates.

As with all other Rheonik meters, this model is based on the patented Omega tube design with increased signal to noise ratio.

This unique design, which offers excellent performance and reliability, has created the most satisfied customers worldwide. Unlike other mass flowmeter manufacturers, Rheonik uses a patented torsion rod swinger with the Omega shape and support bars which results in high accuracy measurement, which is independent of pressure, even at very low flow velocities. The meter has also extremely good repeatability and high stability for critical applications.

### **APPLICATIONS**

Suitable for virtually any mass flow application such as:

- General flow control
- Dosing
- Batching
- Injections
- Filling

### **FEATURES**

The outstanding features include:

- Suitable for pressures up to 868 bar
- Typical measuring ranges from 0.004 kg/min to 0.6 kg/min
- Minimal flows as low as 0.0015 kg/min
- Available as single pipe system for sanitary applications / CIP suitable
- Flow Accuracy of 0.10%
- Repeatability better than 0.05%
- Extra compact design with minimal space requirement
- EEx Approvals (i.e. ATEX, CSA, ...)
- Custody Transfer Approvals (i.e. PTB, NMI...)

### **ADVANTAGES**

- No pressure effect – no deterioration of accuracy due to pressure changes by the patented Omega Shape
- Better performance than thermal meter
- Patented torsion swinger design assures longest life time and increased safety (low stress in welds and increased wall thickness against abrasion)
- No moving parts – practically no maintenance
- Removable connection block

[www.rheonik.com](http://www.rheonik.com) - the mass flowmeter experts

## PERFORMANCE RHM 015

Max Flow 0.6 kg/min (1.32 lb/min)

### 1) Standard Models

Rates / turndown ratio	in kg/min	in lb/min	error in % of reading
nominal rate $Q_{nom}$	0.600	1.323	0.15
$0.2 * Q_{max}$ (5:1)	0.120	0.265	0.20
$0.1 * Q_{max}$ (10:1)	0.060	0.132	0.20
$0.05 * Q_{max}$ (20:1)	0.030	0.066	0.20
$0.0125 * Q_{max}$ (80:1)	0.008	0.017	0.50

Typical $\Delta P$ in bar (psi)	
1 cP	100 cP
1.9 (26)	54.6 (792)
0.1 (1.6)	10.9 (159)
~ 0 (0.8)	5.5 (79.1)
~ 0 (0.4)	2.8 (39.9)
~ 0 (0)	0.7 (10.5)

### 2) Optimized Low Flow Models<sup>(\*)</sup> / optimized to be operated between $0.5 * Q_{max}$ and $0.005 * Q_{max}$

$0.5 * Q_{max}$ (1:1)	0.300	0.661	0.15
$0.01 * Q_{max}$ (50:1)	0.006	0.008	0.30
$0.005 * Q_{max}$ (100:1)	0.003	0.004	~ 0.75 <sup>(**)</sup>

0.5 (7.9)	27.3 (395)
~ 0 (0)	0.5 (7.9)
~ 0 (0)	0.3 (3.9)

<sup>(\*)</sup> serial/single path version offers the same accuracy at half the flow ( $Q_{max} = 0.3$  kg/min)

<sup>(\*\*)</sup> around 0.50 - 1 % accuracy depending on the installation conditions

### 3) Gold Line Models / application fine tuned meters

$1 * Q_{nom}$ (1:1)	0.600	1.323	0.10
$0.1 * Q_{nom}$ (10:1)	0.060	0.132	0.10
$0.05 * Q_{nom}$ (20:1)	0.030	0.066	0.12

1.9 (26.9)	54.6 (792)
~ 0 (0.8)	5.5 (79.1)
~ 0 (0.4)	2.8 (39.9)

**Repeatability** better  $\pm 0.05$  % of rate  
**Temperature** better  $\pm 1^\circ C$

#### Standard Models

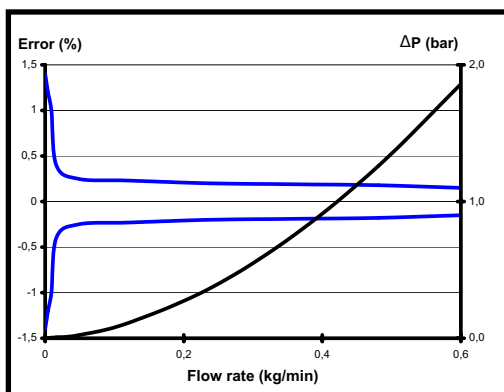

#### Gold Line Models

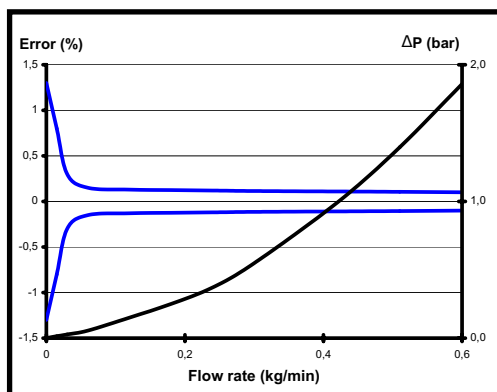

For serial (single pipe/path) sanitary design  $Q_{max}$  is 0.3 kg/min (50%). Data above refer to standard wall thickness.  
 Error of reading (including zero drift) indications refer to reference conditions  $H_2O$ , 18-24°C (66-76°F), 1-3 bar (15-45 psi).  
 RHM sensor do not suffer from pressure effect due to torsional oscillation and semi circle (non-deforming) measurement section.  
 Temperature changes of  $\pm 25^\circ C$  around the operating point are negligible.  
 Pressure drop refers to Newton liquids, with parallel measuring loops and block/manifold connection.  
 Nominal flow refers to approx. 10 m/s (33 ft/sec) velocity in measuring loops for best performance.  
**Calibration to customer range, with increased accuracy, possible.**

## GENERAL OUTLINE DIMENSIONS RHM 015

**Type I** (w/ removable manifold block - serial [SM0] / parallel [PM0] / PTFE seals)

**Thread type:**

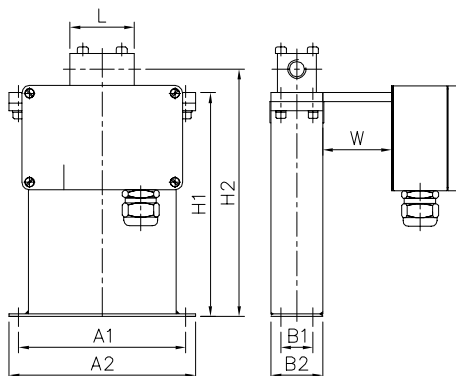

Weight approx. 2.5 kg (5.5 lb)

**Flange type:**

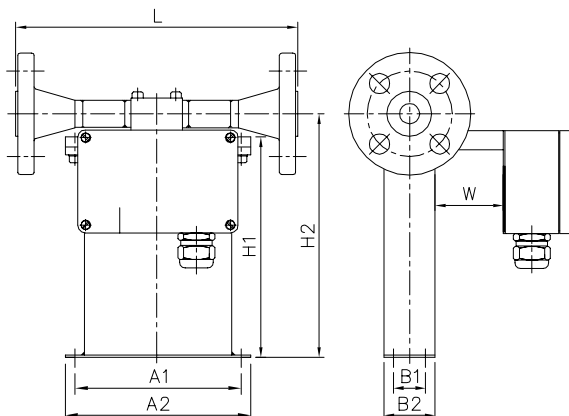

Weight approx. 3.5 kg (7.7 lb)

A1=130 mm (5.12")  
A2=145 mm (5.71")

B1=25 mm (0.98")  
B2=40 mm (1.57")

H1=172 mm (6.77")  
H2=188 mm (7.40")  
H2=196.5 mm (7.74") for  
brazed block version

W=0 mm for NT and ET temperature models and W=100 mm for HT temperature models<sup>(\*)</sup> (see pages 6 & 7).  
For ET1 and ET2 temperature models, terminal box will be replaced by 2 meters free teflon cable.

Process Connection		Face to face length (L) <sup>(**)</sup>	Order Code
Thread Standard	G ¼" female	50 mm (1.97")	G1
	NPT ¼" female	50 mm (1.97")	N1
Thread Optional	Autoclave / Butech thread	70 mm (2.76")	P1
	M20 x 1.5	70 mm (2.76")	XX

Flange Standard	½" CL 150 acc. ANSI B16.5	220 mm (8.67")	A1
	½" CL 300 acc. ANSI B16.5	220 mm (8.67")	A2
	½" CL 600 acc. ANSI B16.5	220 mm (8.67")	A3
	DN15 / PN40 acc. DIN 2635 - C	220 mm (8.67")	D1
	DN15 / PN100 acc. DIN 2637 - E	220 mm (8.67")	D2
Flange Optional	½" CL 900 / 1500 acc. ANSI B16.5	300 mm (11.82")	A6
	½" / CL 2500 acc. ANSI B16.5	300 mm (11.82")	A8
	DN15 / PN160 acc. DIN 2638 - E	220 mm (8.67")	D3
Special	½" JIS flanges	standard - 220 mm (8.67")	XX
	Swagelok	standard - 190 mm (7.48")	XX
	VCR	standard - 190 mm (7.48")	XX
	Novaswiss	standard - 190 mm (7.48")	XX

<sup>(\*)</sup> Type II or Type III preferred - see next pages.

<sup>(\*\*)</sup> Customization possible on request.

Our standard seals are PTFE - Manifold block on request available without seals but with brazed connection block.  
The finish type of our ANSI flanges is RF/SF (AARH 125-250 (µinch) - Ra 3,2 up to 6,3 (µm)). Others available on request.  
Above table only shows our general process fittings.  
For further customization with regard to face to face length and special fittings please contact your local agent.

## GENERAL OUTLINE DIMENSIONS RHM 015

**Type II** (sealless welded, parallel measuring loops w/o seals [PF0])

**Flange type:**

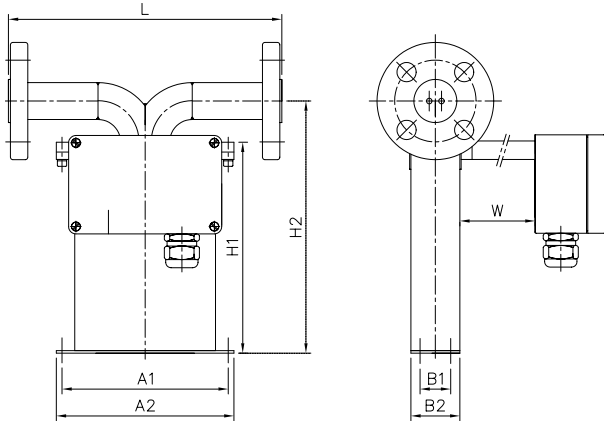

Weight approx. 3.5 kg (7.7 lb)

**Special fittings:**

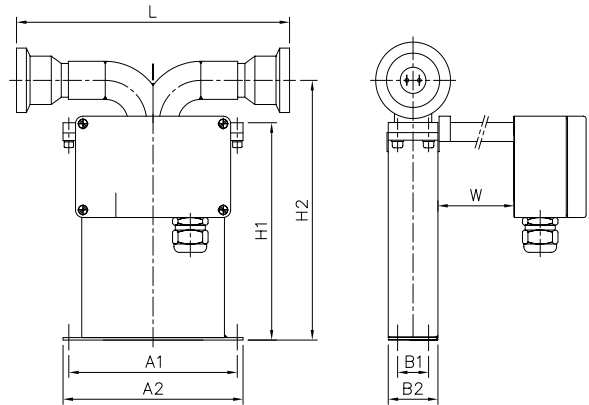

Weight approx. 3.5 kg (7.7 lb)

A1=130 mm (5.12")  
A2=145 mm (5.71")

B1=25 mm (0.98")  
B2=40 mm (1.57")

H1=172 mm (6.77")  
H2=205 mm (8.07")

W=0 mm for NT and ET temperature models and W=100 mm for HT temperature models (see pages 6 & 7).  
For ET1 and ET2 temperature models, terminal box will be replaced by 2 meters free teflon cable.

	Process Connection	Face to face length (L) <sup>(*)</sup>	Order Code
Standard	½" CL 150 acc. ANSI B16.5	220 mm (8.67")	A1
	½" CL 300 acc. ANSI B16.5	220 mm (8.67")	A2
	½" CL 600 acc. ANSI B16.5	220 mm (8.67")	A3
	DN15 / PN40 acc. DIN 2527 - C	220 mm (8.67")	D1
	DN15 / PN100 acc. DIN 2527 - E	220 mm (8.67")	D2
Optional	½" CL 900 / 1500 acc. ANSI B16.5	300 mm (11.82")	A6
	½" / CL 2500 acc. ANSI B16.5	300 mm (11.82")	A8
	DN15 / PN160 acc. DIN 2527 - E	220 mm (8.67")	D3
Special	½" JIS flanges	standard - 220 mm (8.67")	XX
	Free pipe ends 12.00 x 1.50 mm	standard - 190 mm (7.48")	XX
	Grayloc or equivalent hubb	standard - 190 mm (7.48")	XX
	Swagelok	standard - 190 mm (7.48")	XX

(\*) Customization possible on request.

The finish type of our ANSI flanges is RF/SF (AARH 125-250 (µinch) - Ra 3,2 up to 6,3 (µm)). Others available on request.  
Above table only shows our general process fittings.

For further customization with regard to special fittings and face to face length please contact your local agent.

## GENERAL OUTLINE DIMENSIONS RHM 015

**Type III** (sealless welded, serial measuring loops - single path w/o seals [SF0])

### Sanitary fittings:

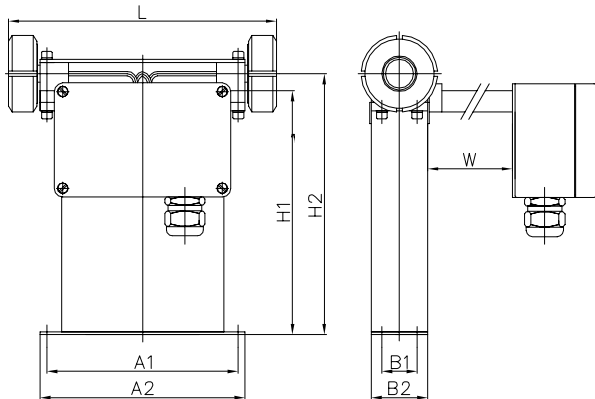

Weight approx. 3 kg (6.6 lb)

A1=130 mm (5.12")  
A2=145 mm (5.71")

B1=25 mm (0.98")  
B2=40 mm (1.57")

### Flange / Other fittings:

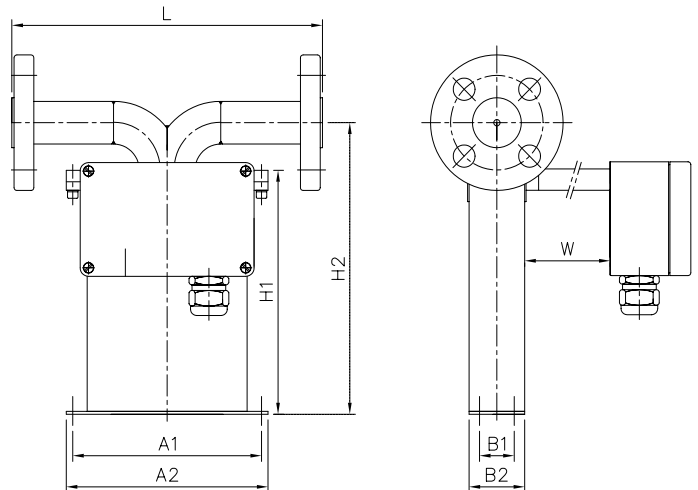

Weight approx. 3.5 kg (7.7 lb)

H1=172 mm (6.77")  
H2=184 mm (7.25") for sanitary fittings  
H2=205 mm (8.07") for flange type

W=0 mm for NT and ET temperature models and W=100 mm for HT temperature models (see pages 6 & 7).  
For ET1 and ET2 temperature models, terminal box will be replaced by 2 meters free teflon cable.

Process Connection		Face to face length (L) <sup>(*)</sup>	Order Code
Sanitary Fittings <sup>(**)</sup>	½" Tri Clamp acc. DIN 32676	190 mm (7.48")	S1
	DN10 / Sanitary acc. DIN 11851	190 mm (7.48")	S2
Flange Other Fittings	½" CL 150 acc. ANSI B16.5	220 mm (8.67")	A1
	½" CL 300 acc. ANSI B16.5	220 mm (8.67")	A2
	DN15 / PN40 acc. DIN 2527 - C	220 mm (8.67")	D1
	Swagelok	standard - 190 mm (7.48")	XX
	Free pipe ends 12.00 x 1.50 mm	standard - 190 mm (7.48")	XX

(\*) Customization possible on request.

(\*\*) Fitting material is 1.4435 / SS 316L.

The finish type of our ANSI flanges is RF/SF (AARH 125-250 (µinch) - Ra 3,2 up to 6,3 (µm)). Others available on request.

Above table only shows our general process fittings.

For further customization with regard to special fittings and face to face length please contact your local agent.

## GENERAL SPECIFICATIONS RHM 015

### Approvals

- ATEX (CESI 02 ATEX 053 X)  
Ex II 1 G, EEx ia IIC T6-T1
- CSA (220705)  
Class I, Div 1 and 2,  
Groups A, B, C and D; Type 3
- Custody Transfer Approvals  
(PTB 1.32-97027224 and NMI TC 3382)
- PED according to directive 97/23/EC:  
available
- 3A Sanitary Approvals

### Electrical connection

- Junction box / aluminium coated (standard)  
IP 65 (Nema 4X)  
(Junction box in SS optional)
- Cable entry M25 x 1.5  
(M20 x 1.5, ½" and ¾" NPT optional)
- Max cable length between RHM and RHE:  
100 m (330 ft)  
200 m (660 ft) only with factory approval

### Housing

- Stainless Steel: 1.4301 / SS 304  
- others on request -
- Protection class: IP 65 (Nema 4X)  
- higher on request -

### Material of wetted parts

- 1.4539 / SS 904L (measuring loops)  
1.4571 / SS 316Ti (process connection)
- Hastelloy C4 on request
- Tantalum on request
- Other material on request

### Pressure rating

- Pressured part of the meter consists of the measuring loops and the connection part. The weaker of both parts decides the maximum allowed operating pressure. Below is the max. operating pressure of the measuring loops<sup>(\*)</sup>.

(\*) These values are only valid for SS 316Ti & SS 904L materials. Statements for others materials on request.

#### Standard version:

- 300 bar @ 120°C (4350 psi @ 248°F)
- 250 bar @ 210°C (3625 psi @ 410°F)
- 200 bar @ 350°C (2900 psi @ 662°F)
- wall thickness is generally 0.2 mm (0.008")

#### Optional high pressure version:

- 400 bar @ 120°C (5800 psi @ 248°F)
- wall thickness is generally 0.25 mm (0.01")

- *Extremely high pressure (up to 850 bar)*  
- on request -

### Temperature rating

- NT Models from -20 to +120°C (-4 to +248°F)
- ET Models from -45 to +120°C (-49 to +248°F)
- ET1 Models from -200 to +50°C (-328 to +122°F)
- ET2 Models from -45 to +210°C (-49 to +410°F)
- HT Models from 0 to +350°C (+32 to +662°F)



- to be continued with the order code on the next page -

[www.rheonik.com](http://www.rheonik.com) - the mass flowmeter experts

## ORDER CODE RHM 015

### Order Code Structure

The order code of the Rheonik Sensors consists of 6 sections (see previous pages / below). Restrictions of combinations may apply. For specials, please comment your needs in plain text / sketches.

#### Temperature Rating

T1	NT Models (Normal Temperature Models) from -20 to +120°C (-4 to +248°F)
TA	ET Models (Extended Temperature Models) from -45 to +120°C (-49 to +248°F)
T2	ET2 Models (Extended Temperature Models) from -45 to +210°C (-49 to +410°F)
T3	ET1 Models (Extended Temperature Models) from -200 to +50°C (-328 to +122°F)
T4	HT Models (High Temperature Models) from 0 to +350°C (+32 to +662°F)

#### Pressure Rating

P1	Standard pressure version (300 bar @ 120°C / 4350 psi @ 248°F) - page 6 -
P2	High pressure version (400 bar 120°C / 5800 psi @ 248°F) - page 6 -
P3	Extremely high pressure version (on request) - page 6 -

#### Construction Type

PM0	Parallel Measuring Loops with removable Block/Manifold and PTFE Seals - page 3 -
SM0	Serial Measuring Loops with removable Block/Manifold and PTFE Seals - page 3 -
PF0	Parallel Measuring Loops Seal Less Welded Version - page 4 -
SF0	Serial Measuring Loops Seal Less Welded Version / Single Path - page 5 -
XXX	Other construction type on request

#### Material of Wetted Parts

M0	1.4539 / SS 904L (measuring loops) 1.4571 / SS 316Ti (connection part)
M4	Tantalum
M5	Hastelloy C4 (measuring loops) / Hastelloy C22 (connection part)
MX	Other material on request

#### Process Connection

XX	Code available on pages 3, 4 and 5.
----	-------------------------------------

#### Hazardous Area Approvals

NN	Without Ex Approvals
AT	ATEX Approvals (CESI 02 ATEX 053 X) - Ex II 1 G, EEx ia IIC T6-T1
CS	CSA Approvals (220705) - Class 1, Div 1 / Group A, B, C, and D; Type 3

### Order Code Example

M# #5 T1 P1 PM0 M0 G1 AT

T1:	NT (Normal Temperature Models) from -20 to +120°C (-49 to +248°F)
P1:	Standard pressure version (300 bar @ 120°C / 4350 psi @ 248°F)
PM0:	Parallel Measuring Loops with removable Block/Manifold and PTFE Seals
M0:	1.4539 / SS 904L (measuring loops) 1.4571 / SS 316Ti (connection part)
G1:	Female Thread G 1/4"
AT:	ATEX Approvals (CESI 02 ATEX 053 X)

M# #5 \_ \_ \_ \_ \_

[www.rheonik.com](http://www.rheonik.com) - the mass flowmeter experts